

Installation Instructions Flat Pack



1.1



1. Assemble frame and notes as shown in images 1.2, 1.3 and 1.4 (see Assembly Guide)

2. Using M10 nuts and 200mm bolts supplied locate through pre drilled holes and secure bolts in place to support in ground pole in concrete. **3 Bars per leg at 120 degree angles. (1.3)**

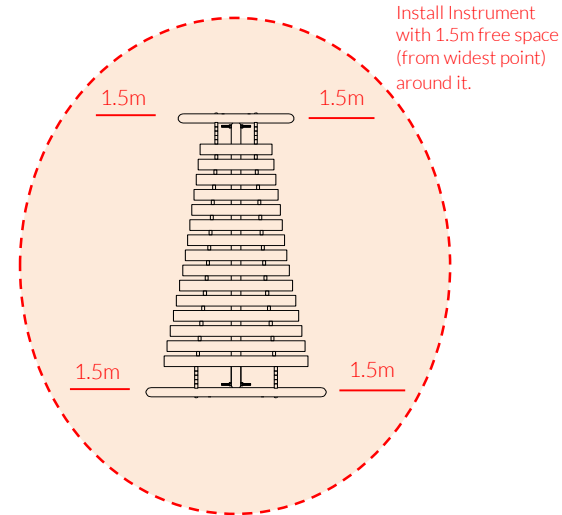

3. Excavate 2 holes for the Marimba legs **250mm diameter by 300mm deep** in desired location upon decision from customer.

4. Locate (lower) legs into holes making sure they are vertical and level prior to concreting in place.

5. Once happy with location of the Marimba, **fill holes using rapid hardening concrete**. Be sure to compact concrete around legs and leave to dry according to manufactures guidelines.

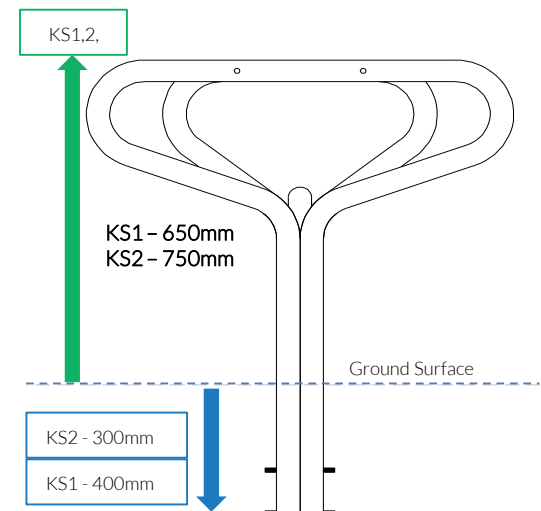

1.2

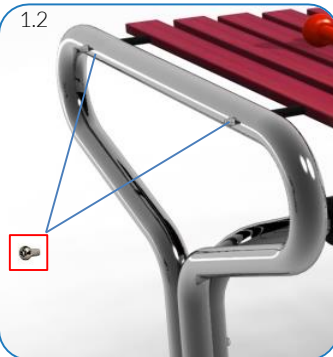

1.3

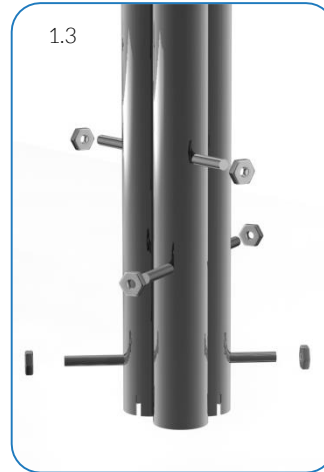

1.4



Metric Conversion:	
250mm/ 10"	
300mm/ 12"	
400mm/ 16"	
650mm/ 26"	
750mm/ 30"	
1.5m/ 59"	

Weight of heaviest part **15kg** (Notes)

Ground Fixed
Marimba
Page 1 of 3



Instrument Components:

- x4
- x2
- x4
- x4
- x4



Ground Fix Components :

- x6
- x12





42 Kg

Assembly Guide PPMARI



Tools:

 x1  x1

TX 40 Driver Bit TX 30 Driver Bit

Ground Fixed
Marimba
Page 2 of 3



Instrument Components:

-  x4
-  x2
-  x4
-  x4
-  x4

Thread Lock Solution Required

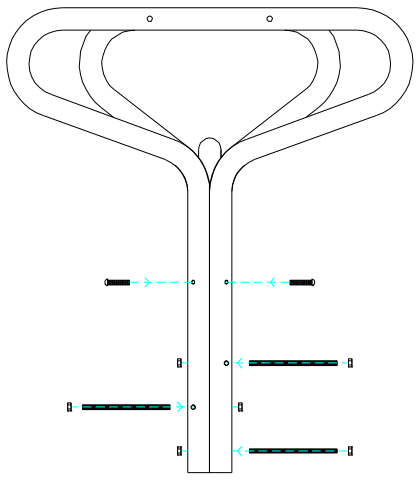



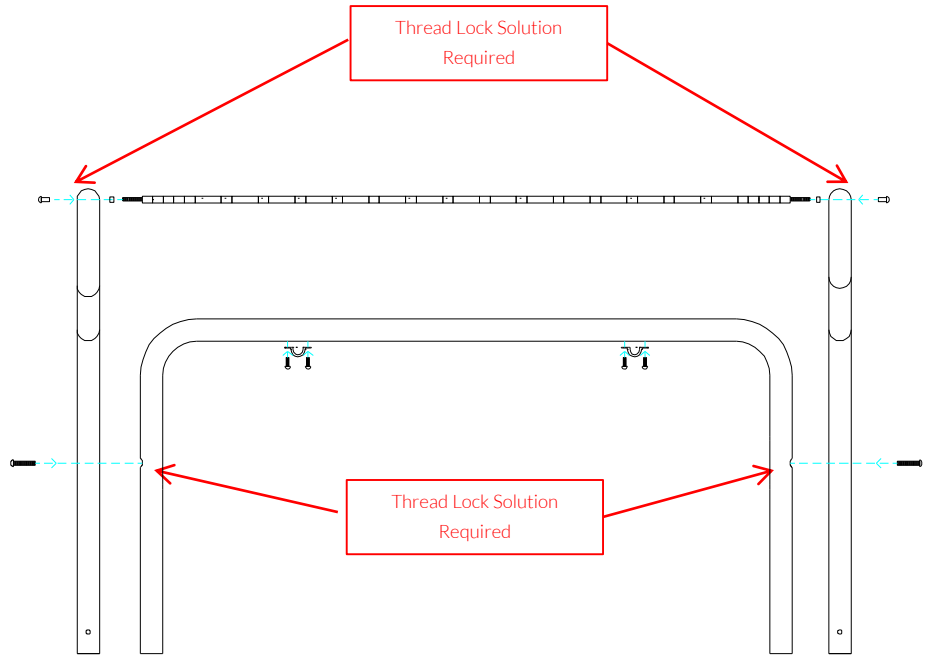



PPMARI SIDE



Thread Lock Solution Required

PPMARI FRONT

COMPONENTS LIST:

-  M10 Nut X12
-  M10x200 Threaded Bar X6
-  M8x60 Pin torx X4
-  M8 Barrel Nut Pin torx X4
-  M8 Square nut X4
-  Saddle Strap X2
-  M6x20 Pin torx X4

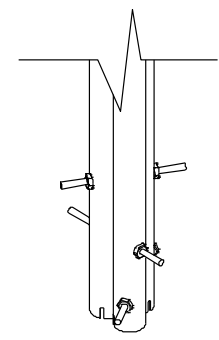
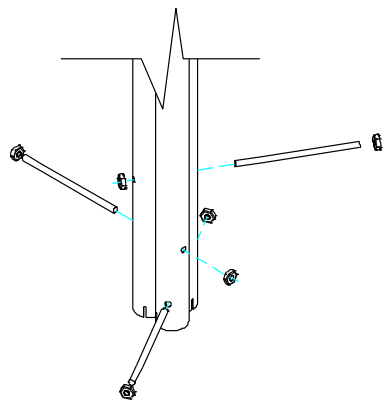

 Pair Large Red Beaters X2

Ground Fix Components:

-  x6
-  x12



42 Kg

Ground Fix Installation

- 1 Excavate 2 holes with a 250mm diameter tapering down to 350mm diameter and 350mm depth

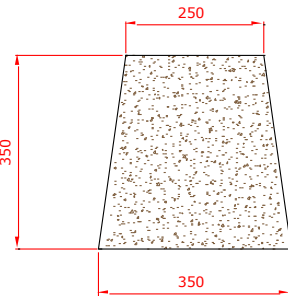
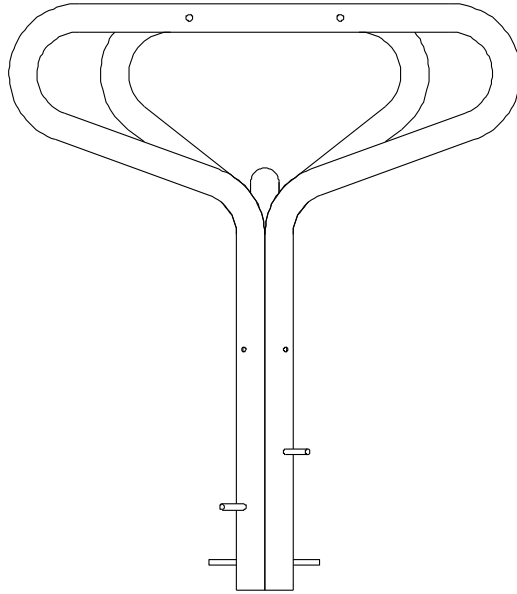

If Marimba needs to be positioned lower a deeper hole can be excavated.

- 2 Compact base of each hole with 50mm of aggregate. Lower ground the instrument into hole (check instrument straight and level before filling with concrete)

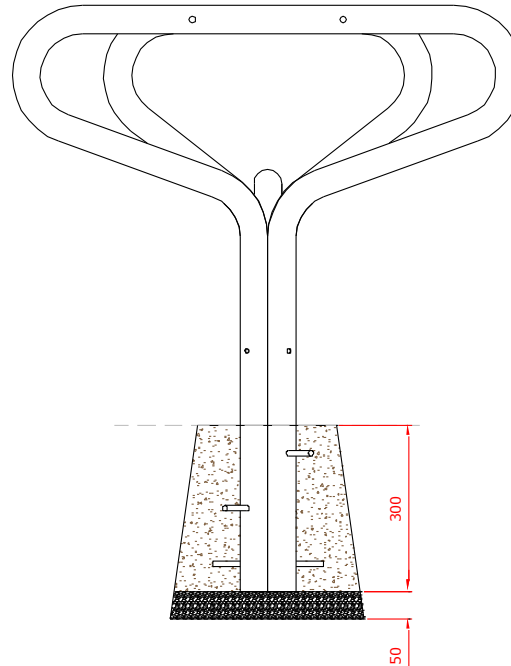

- 3 Fill hole with fast drying concrete to manufacturers specifications.

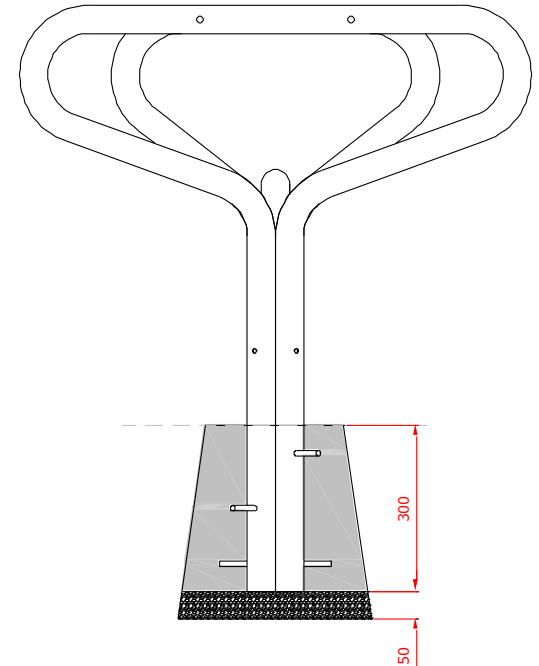

Ground Fixed

Marimba
Page 3 of 3



Components:



x6

M10x200 Threaded Bar



x12

M10 BZP Nut

Metric Conversion:

50mm/ 2"
250mm/ 10"
300mm/ 12"
350mm/ 14"

Foundations should not present a hazard. These foundations are recommended as a guide, for more information on foundation details for various surface see Part 7 of BS EN 1176.