

# Product Information

## Virtuoso Shake, Rattle & Roll with Alu Posts

BS EN 1176 - Designed to British & European Standards

### MATERIALS

**Panels** - Two Colour High Density Polyethylene (HDPE)

**Post** - Extruded aluminium post with powder coat finish

**Wheel Surround** - Stainless steel

### SUPPLY METHOD

**Wheel** - Assembled

**Posts** - Includes post caps & fixings



### DIMENSIONS

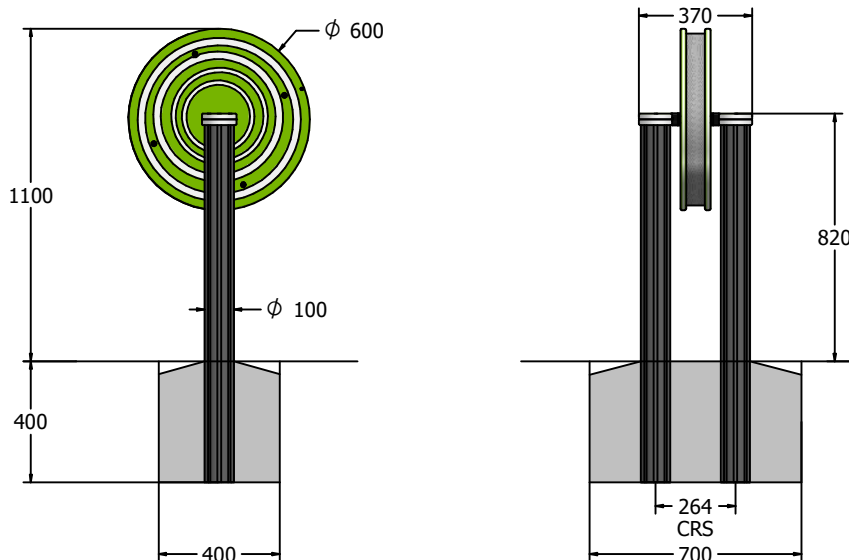

### TECHNICAL

**Age Range:** 2+ Years  
**Largest Part:** Post & Cap 1220 x  $\phi$ 110mm  
**Heaviest Part:** Wheel Assembly 10.5kg Approx.  
**Total Weight:** 20.5kg Approx.  
**Surfacing:** N/A