

# Installation Instructions

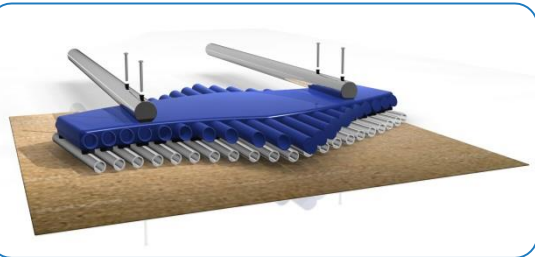

## Surface Fixed

Sonora  
Page 1 of 3



**1. Carefully lay 2 x legs on a level surface and insert M8x120 bar and Counter Sunk Barrel nuts.** Using packing box as protection lay instrument note side down on the card. Line up pre drilled holes in the backboard with the legs and ensure the instrument is aligned square with the legs. **Fix** in place using **M8x30mm barrel nuts** supplied (see installation guide)

**2. Attach surface plates to each leg with M10x70mm and Barrel nuts supplied. ( See Surface Fix Installation Sheet)**

**3. Fix Surface Plates to level surface using Coachscrews, Rawlbolts, chemical anchors or similar as deemed appropriate by Installer.**

(It is your responsibility to ensure that the existing surface is suitable to receive the appropriate fixing)

**4 Make sure all fixings are covered and secure using cover caps provided**

**5. Beaters can be fixed to Stainless Steel posts with fixings provided**

Install Instrument with 1.5m free space (from widest point) around it.

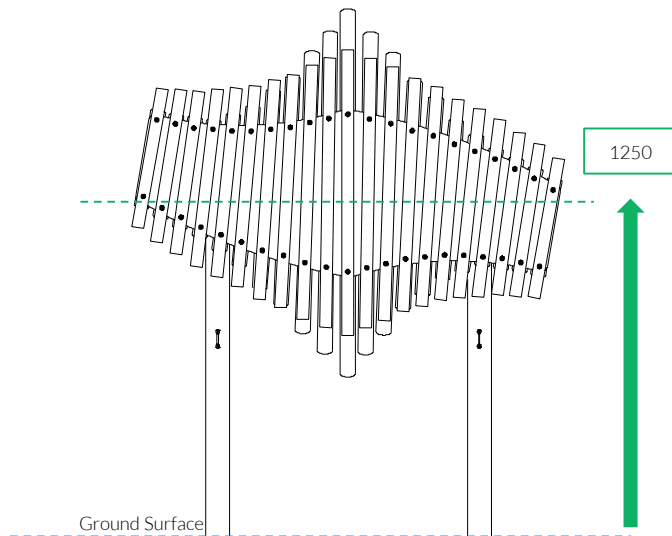
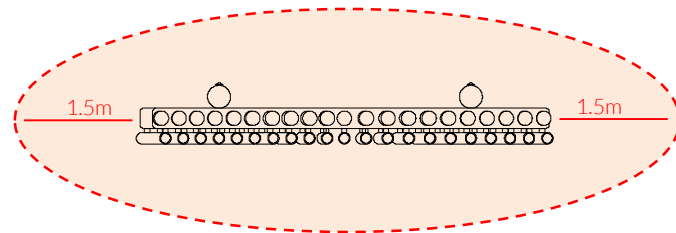

Metric Conversion:  
600mm/ 1ft 11 5/8 "  
900mm/ 35"  
1100mm/ 43"  
1.5m/ 59"

### Components:

-  x4  
M8 Barrel Nut
-  x2  
Eye Straps
-  x4  
M6x20mm Secure Screw
-  x4  
M8 CSK Barrel Nut



Weight of heaviest part 40kg



Pair Small Beaters X2

### Surface Fix Components:

-  x8
-  x2
-  x2

Ground Anchors not supplied





BS EN 1176

52 Kg

# Assembly Guide PPSWAV



**Tools:**

 x1     x1

TX 45 Driver Bit    TX 30 Driver Bit

## Ground Fixed

Sonora  
Page 2 of 3



### Components:

-  x4
-  x2
-  x4
-  x4

Thread Lock Solution  
Required (Not Supplied)

Thread Lock Solution  
Required (Not Supplied)



 Pair Small Beaters X2

### Surface Fix Components:

-  x8
-  x2
-  x2

Ground Anchors  
not supplied

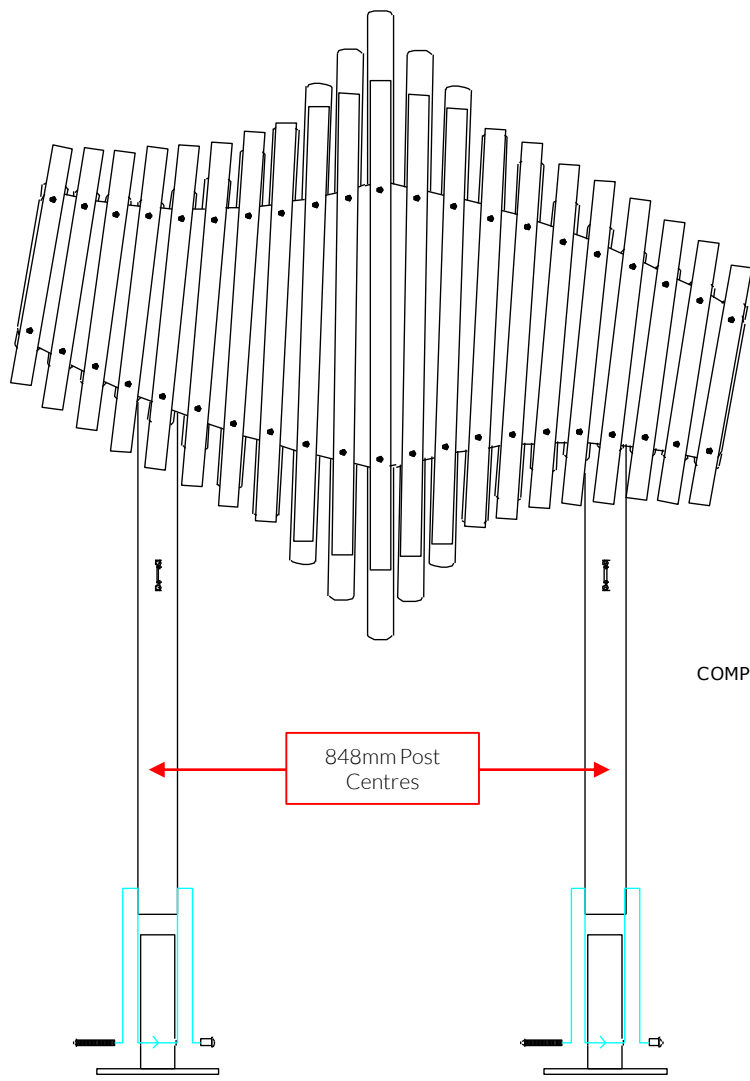
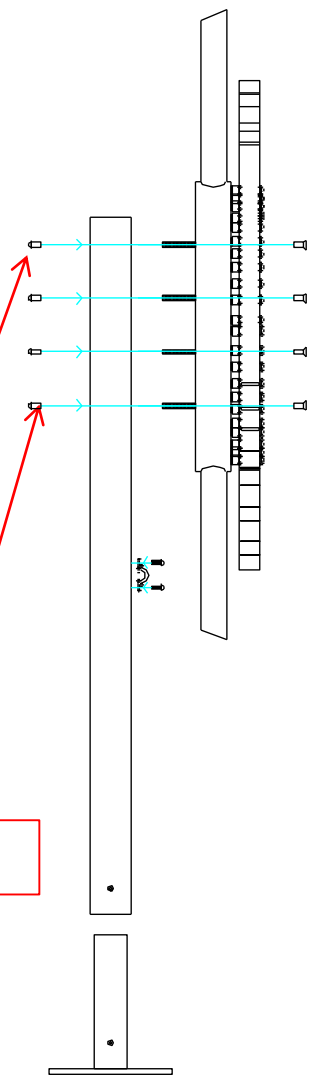

### COMPONENTS LIST:

-  Saddle Strap X2
-  M6x20 Pin torx X4
-  M8 Barrel Nut Pin torx X4
-  M10x70 Pin torx X2
-  M10 Barrel Nut Pin torx X2
-  M8 CSK Barrel Nut Pin torx X4
-  M8 x120 Stud X4

37 Kg

# Surface Fix Post Installation

Tools:



x2  
TX 45 Driver Bit

## Surface Fixed

Sonora  
Page 3 of 3



### Components:



x2

M10 Barrel Nut



x2

M10x70 Security Screw



x8

2 Part Cover Cap

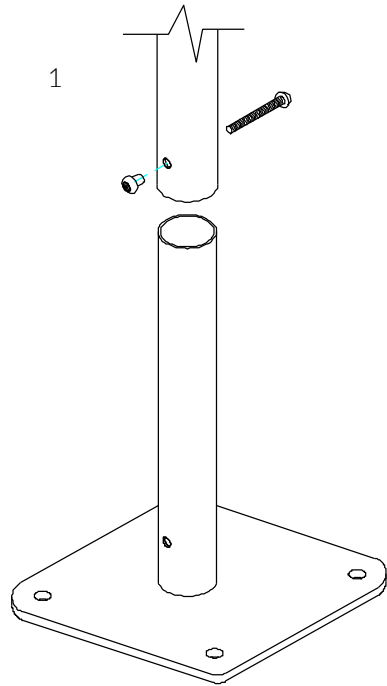

Locate the Surface fix Plate into the leg of the instrument.

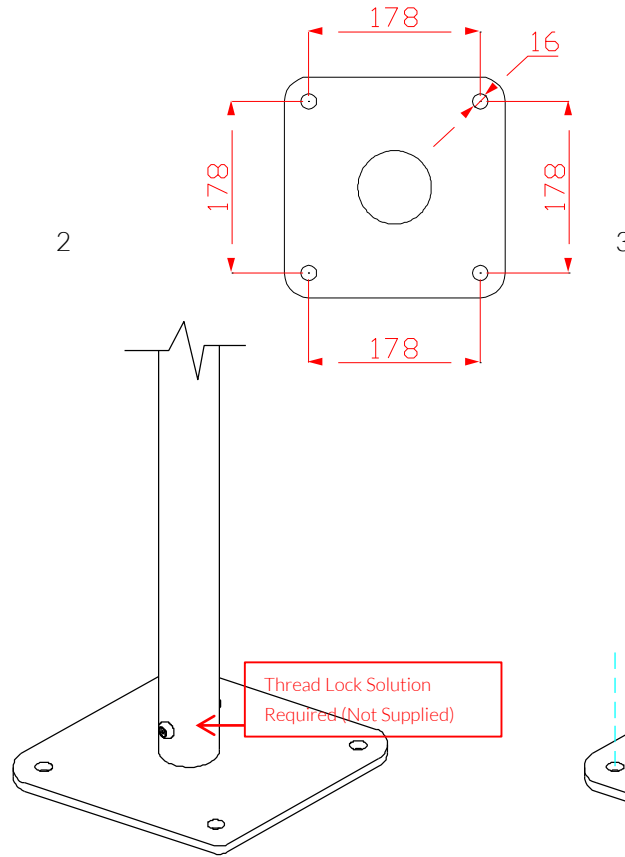

Fix instrument to Surface fix plate using M10 bolt and Barrel Nut and use **thread locking solution** to prevent fixings working loose.

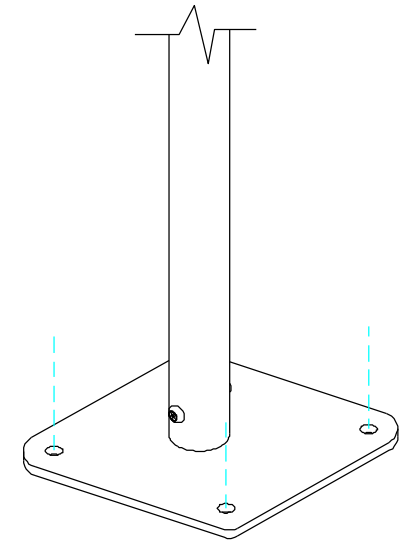

Fix Surface Plate to the ground surface **Ground Anchors Not provided** cover fixings with caps provided

Thread Lock Solution Required (Not Supplied)



MADE IN BRITAIN

BSEN 1176