

MODULAR SEATING

YOUR SEAT IS SUPPLIED PART-ASSEMBLED WITH JUST AN END BOX TO FIT



Pre-drilled location holes

TOOLS REQUIRED FOR GROUND FIXING:
17mm Socket
10mm Masonry Bit

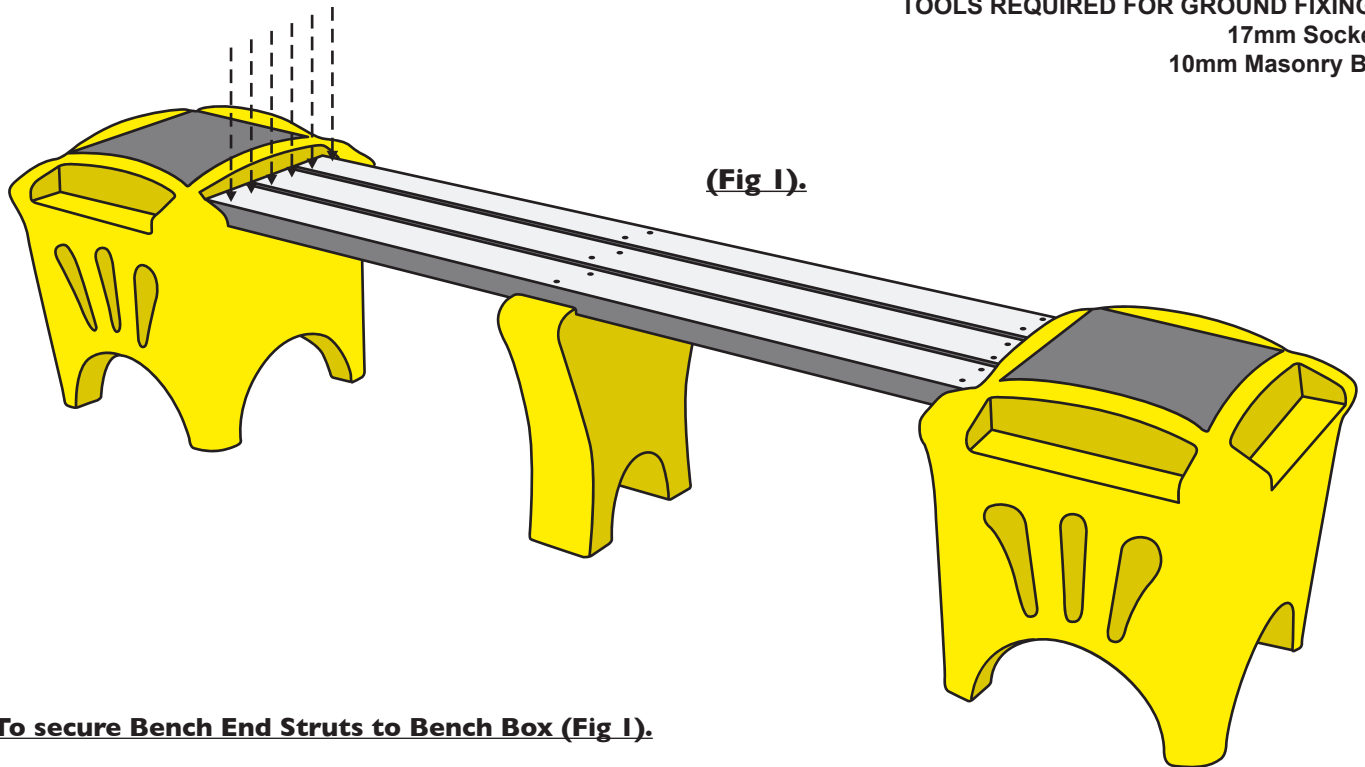

To secure Bench End Struts to Bench Box (Fig 1).

Position the Bench End Struts onto the Bench Box.

Drill a 2mm diameter pilot hole into the Bench Box through the pre-drilled location holes in the struts.

Use the screw bit provided to screw the 50mm long fixing screws supplied through the bench struts and into the Bench Box.

The units should now be fixed together in the required position.

To secure the assembled unit to the ground. (Concrete, Paving, Tarmac).

Use the ground-fixing bolts supplied; 2 per end box, to drill and fix the products to the ground.

Drill 10mm diameter holes into the ground to a depth of 120mm and use a 17mm ratchet spanner to tighten the bolts supplied into the ground.

To secure black Flat-Top Vinyl panels (if requested to be supplied loose).

Place a vinyl panel in position on the coloured box.

Drill four 6.0mm diameter holes through the location holes in the corners of the black vinyl panels and through the coloured end-box.

Place a black plastic rivet in each hole.

Hammer the rivet into place until the rivet pin is flat.

The black panel should now be fixed to the coloured box.