

Installation Instructions

Ground Fixed

Harmony Flower
Page 1 of 2



Instrument
Components:

Metric Conversion:
400mm/ 16"
1345mm/ 52 61/64"
1095mm/ 43 7/64"
945mm/ 37 13/64"
1.5m/ 59"

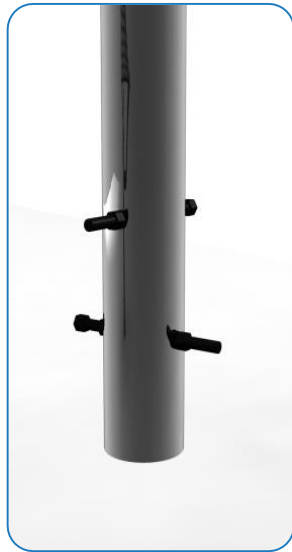

Weight of heaviest part **5kg** (Large Flower)

1. Unpack ground fixing leg 1no.

2. Lay packaging out on floor or assemble on non-abrasive surface to prevent marking of polished stainless steel.

3. Insert ground fix post (opposite end to polished domes) and secure in place using 1no. M10 x 40mm Screw and Barrel Nut provided. Tools required TX 45 Driver Bits)

4. Insert M10 x 200mm threaded bar and 4no. M10 nuts provided
Tools required 2no. 17mm metric spanner/wrench ($11/16$ inch or alternatively using adjustable wrench)

5. Excavate a hole for the frame **250mm diameter by 450 deep** in desired location upon decision from customer. (See Ground Fix Post Installation)

6. Locate (lower) frame into hole making sure that the flowers are level and upright.

7. Once happy with location of the Flowers, **fill hole using rapid hardening concrete**. Be sure to compact concrete around legs and leave to dry according to manufactures guidelines.

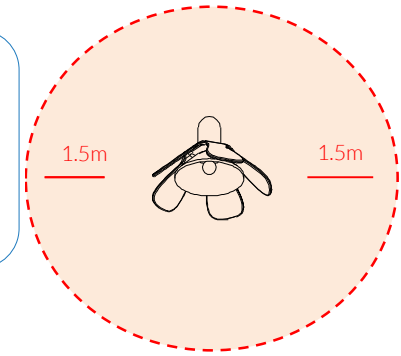

Install Instrument with 1.5m free space (from widest point) around it.

Large 1345mm
Medium 1095mm
Small 945mm

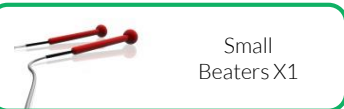
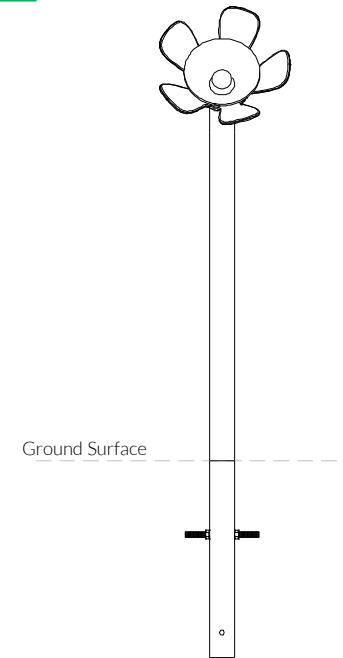
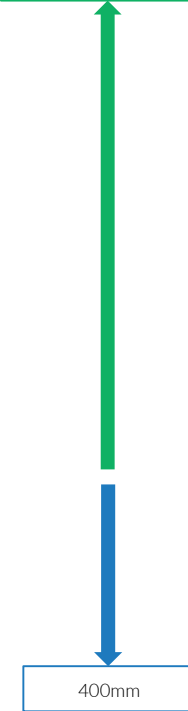

Ground Fix Components:

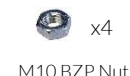

Spares available from percussionplay.com or from your local distributor

14 Kg

Ground Fix Post Installation

Tools:

x1
TX 45 Driver Bit

Foundations should not present a hazard. These foundations are recommended as a guide, for more information on foundation details for various surface see Part 1 of BS EN 1176.

Ground Fixed

Harmony Flower
Page 2 of 2

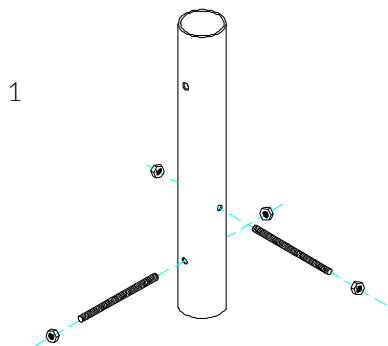

1 Insert M10x 200 Threaded bar into pre drilled holes in Ground Fixing Post

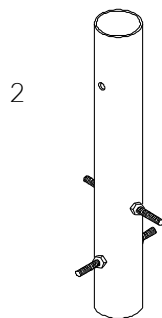

2 Fix M10x 200 Threaded bar in place using M10 Nuts

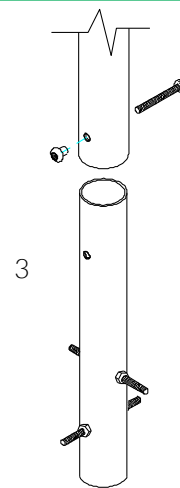

3 Locate the Ground fix Post into the leg of the instrument.

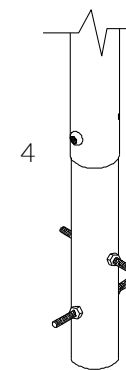

4 Fix instrument to Ground fix post using M10 bolt and Barrel Nut and use **thread locking solution** to prevent fixings working loose.

Components:

- x2
M10x200 Bolt
- x4
M10 Nut
- x1
M10x40 Security Screw
- x1
M10 Barrel Nut

Thread Lock Solution Required

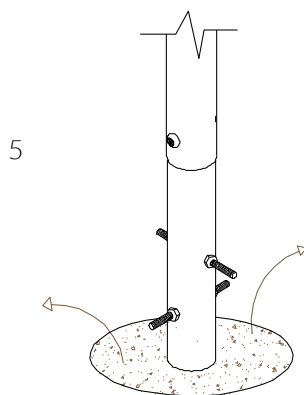

5 Excavate 1 hole with a 250mm diameter tapering down to 350mm diameter and 450mm depth

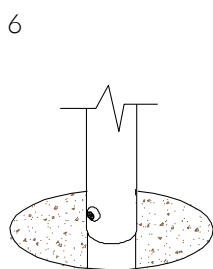

6 Compact base of hole with 50mm of aggregate. Lower ground Fix post attached to instrument into hole (check instrument straight and level before filling with concrete)

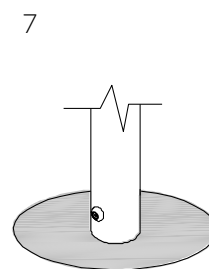

7 Fill hole with fast drying concrete to manufacturers specifications.

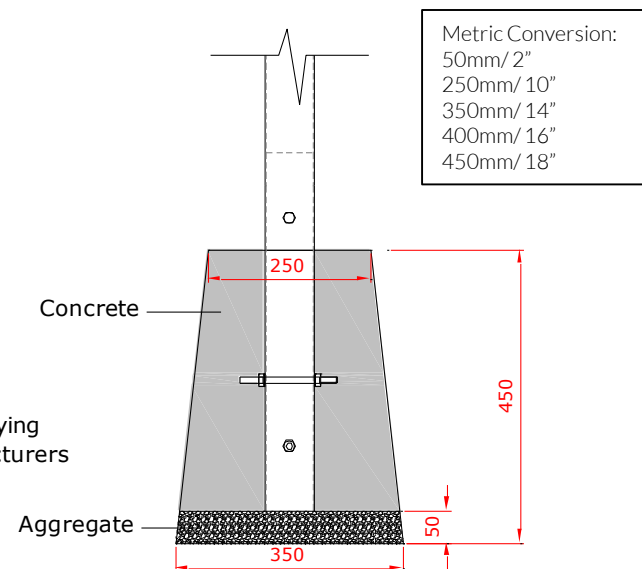

Metric Conversion:
50mm/ 2"
250mm/ 10"
350mm/ 14"
400mm/ 16"
450mm/ 18"