

Installation Instructions



Surface Fixed

Freechimes
Alto/ Soprano
Page 1 of 3



Metric Conversion:
600mm/ 24"
800mm/ 31"
950mm/ 37"
1200mm/ 47"
1.5m/ 59"

Weight of heaviest part 8.35kg (Freechimes)

1. Carefully lay 2 x legs on a level surface and check distance between legs is equal. Line up pre drilled holes in the backboards with the holes in legs and ensure the instrument is aligned square with the legs. Fix in place using M8x40mm screws supplied (see installation guide)

2. Attach Surface Fixing posts to legs (See Surface Fix Post Installation Sheet)

3. Locate Instrument in desired location and mark holes to fix to desired surface.

4. Fix Surface Plate to level surface using Coachscrews, Rawlbolts, chemical anchors or similar as deemed appropriate by Installer.

(It is your responsibility to ensure that the existing surface is suitable to receive the appropriate fixing)

5. Make sure all fixings are covered and secure using cover caps provided

6. Beaters can be fixed to Steel posts with fixings provided

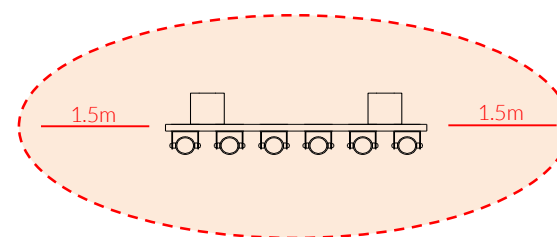

Install Instrument with 1.5m free space (from widest point) around it.

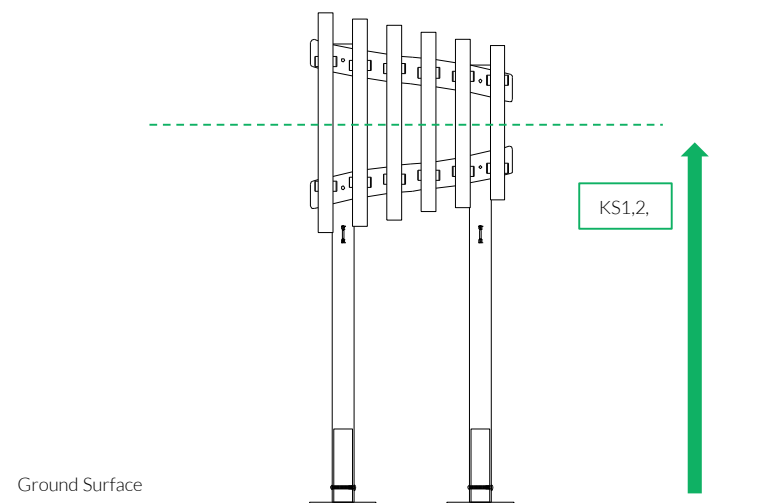

KS1 - 800mm
KS2 - 950mm
Adult - 1200mm



Pair Small Beaters X1

Ground Fix Components:



2 Part Cover Cap

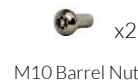

M10 Barrel Nut



M10x70 Security Screw

16 Kg

Assembly Guide PPFREC



Surface Fixed

Freechimes
Alto/ Soprano
Page 2 of 3



Components:



Eye Straps
X2



M6x20mm
Secure Screw
X4



M8x40mm
Secure Screw
X4

709mm Diatonic Post Centres

472mm Pentatonic Post Centres

Thread Lock Solution
Required (Not Supplied)

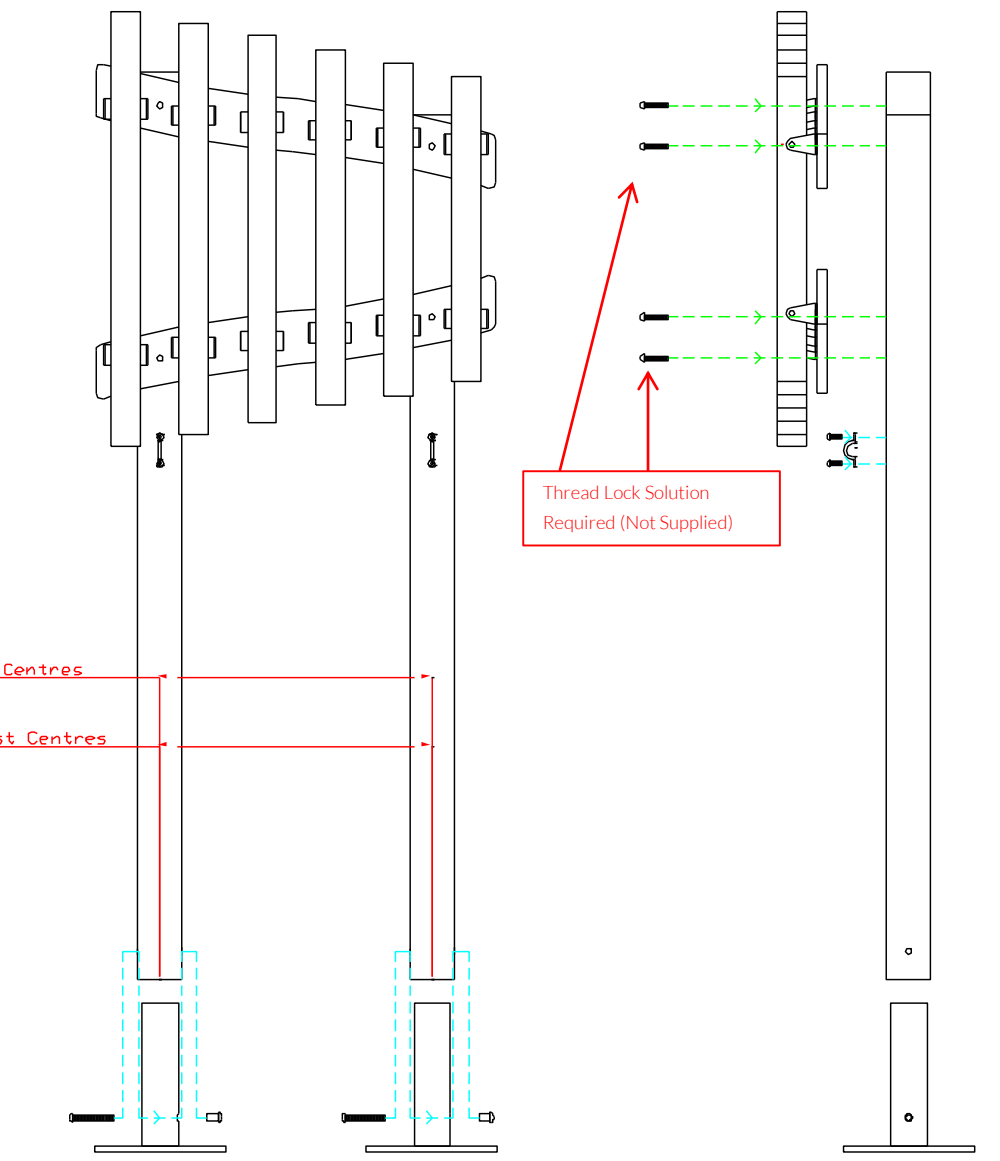

Tools:

- x1
TX 30 Driver Bit
- x2
TX 45 Driver Bit

COMPONENTS LIST:

- Saddle Strap X2
- M6x20 Pin torx X4
- M8x40 Pin Torx X4
- M10x70 Pin torx X2
- M10 Barrel Nut Pin torx X2

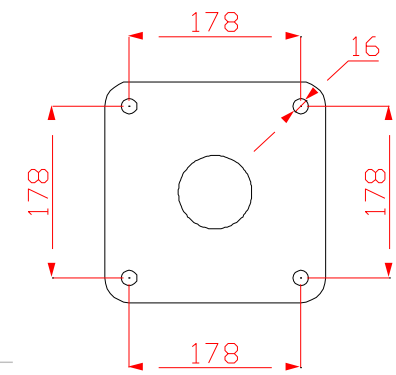

Pair Small
Beaters X1

Ground Fix
Components:



2 Part Cover Cap x8



M10 Barrel Nut x2



M10x70 Security Screw x2

16 Kg

Surface Fix Post Installation



Tools:



Surface Fixed

Freechimes
Alto/ Soprano
Page 3 of 3



Components:



M10 Barrel Nut



M10x70 Security Screw



2 Part Cover Cap

Thread Lock Solution
Required (Not Supplied)



MADE IN
BRITAIN

BSEN 1176

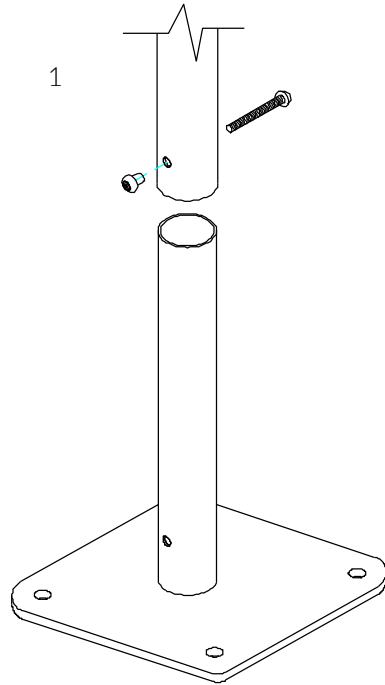

1
Locate the Surface fix Plate into the leg of the instrument.

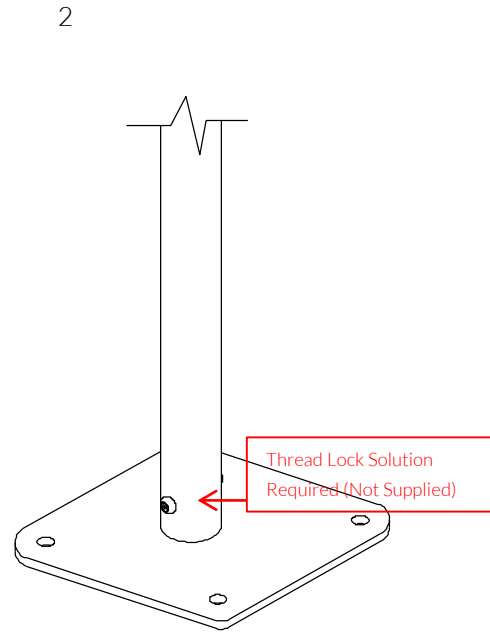

2
Fix instrument to Surface fix plate using M10 bolt and Barrel Nut and use **thread locking solution** to prevent fixings working loose.

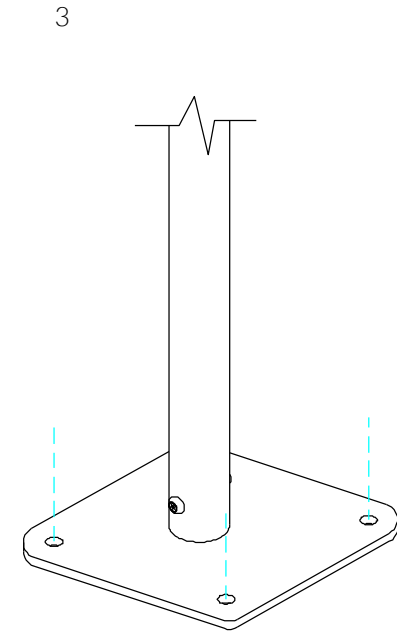

3
Fix Surface Plate to the ground surface **Ground Anchors Not provided** cover fixings with caps provided