

Product Specification



AMVFA-AP-FIESFIRE3PT

PlayTronic Fire Engine Play Panel

3
YEAR
ELECTRONICS
GUARANTEE

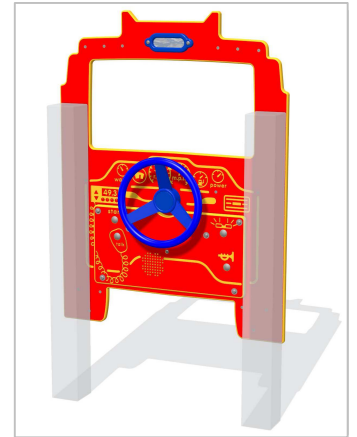

Includes Moving Steering Wheel and
(((PlayTronic)))
 Sound / Effects
 Siren, Engine, Horn and
 Communications Radio.

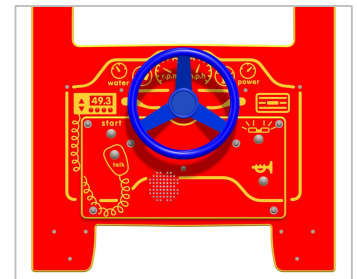

Details shown are for panel only.

To be fixed on to posts or wall mounted.

Contact AMV Playground
 Solutions for supply of suitable
 posts or wall fixings.

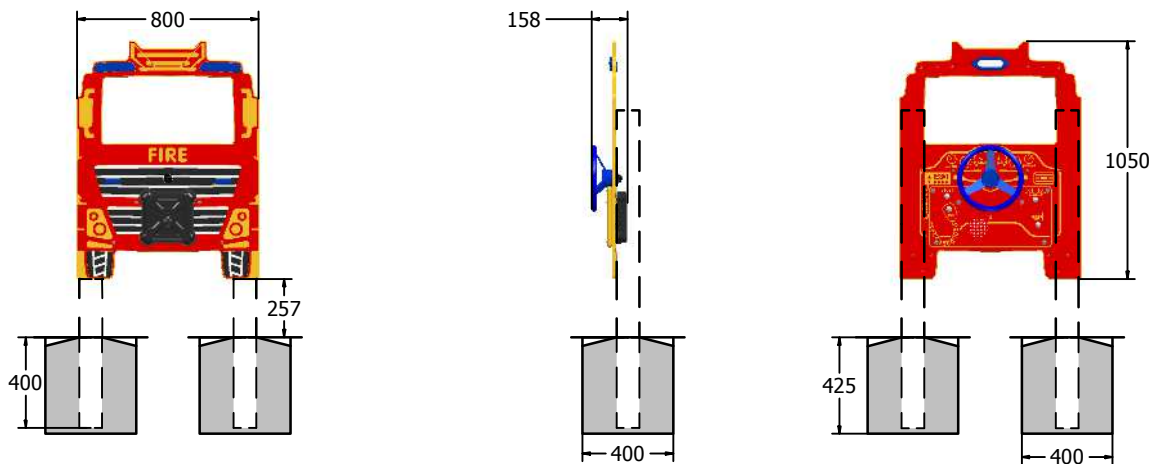

Age Range: 2+ Years
 Largest Part: Complete Assembly - 800 x 1050
 Total Weight: Complete Assembly - 13.1Kg
 Surfacing : N/A

Minimum Inspection Schedule	
Inspection Type	Inspection Frequency
Visual	Every Month
Functionality	Every Month
Comprehensive	Every 6 Months

Designed to British & European
 Standard BS EN 1176

Material: **Design Panel** - Two Colour High Density Polyethylene (HDPE) with orange peel texture finish

Colour Choices: **Design Panel** - Broad selection available, visit the website below for further details