

Product Specification

AMVFA-AP-FIESFIRE3

Fire Engine Play Panel



Details shown are for panel only.

To be fixed on to posts or wall mounted.

Contact AMV Playground Solutions for supply of suitable posts or wall fixings.

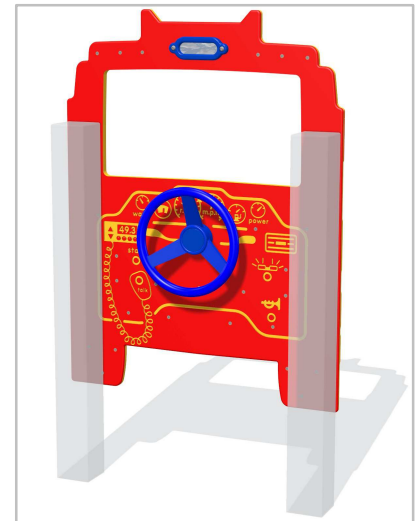

Double Sided Panel

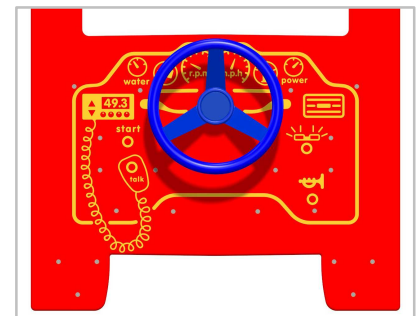

Includes Moving Steering Wheel

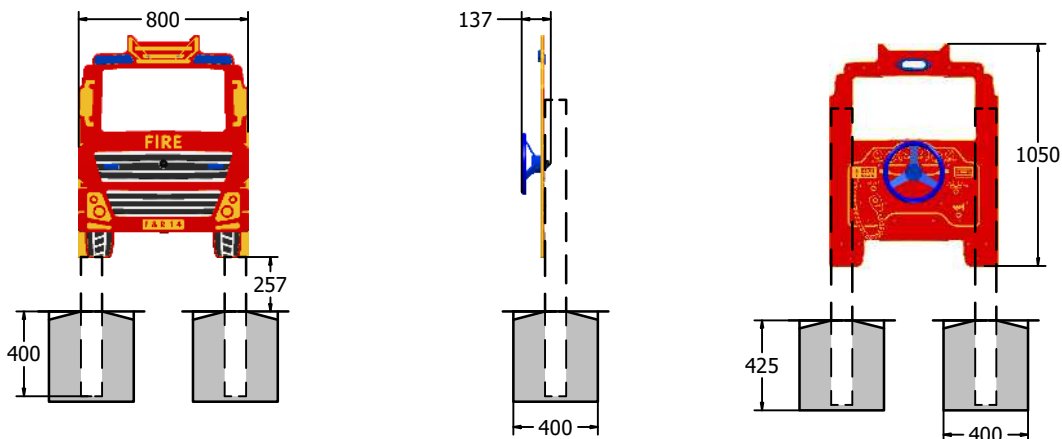

Age Range: 2+ Years
 Largest Part: Complete Assembly - 800 x1050
 Total Weight: Complete Assembly - 11Kg
 Surfacing : N/A

Minimum Inspection Schedule	
Inspection Type	Inspection Frequency
Visual	Every Month
Functionality	Every Month
Comprehensive	Every 6 Months

Designed to British & European Standard BS EN 1176

Material: **Design Panel** - Two Colour High Density Polyethylene (HDPE) with orange peel texture finish

Colour Choices: **Design Panel** - Broad selection available, visit the website below for further details