

# Product Information

## Underwater Scene with Cut-out and Clear Dome

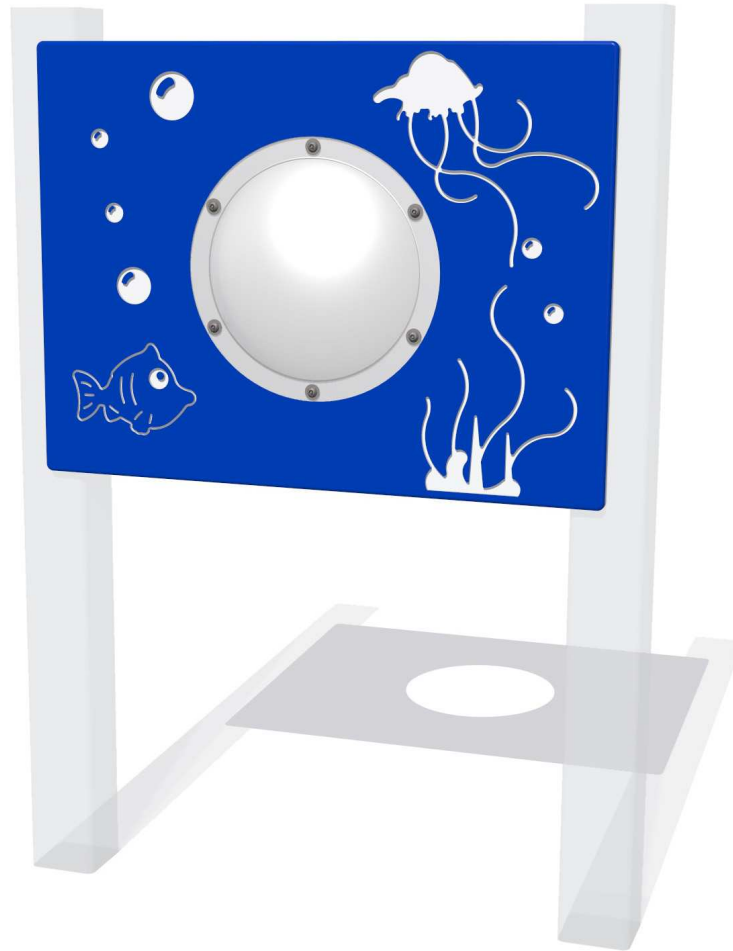

Details shown are for panel only.

To be fixed on to posts or wall mounted.

Contact AMV Playground Solutions for supply of suitable posts or wall fixings.

Designed to British & European Standard BS EN 1176

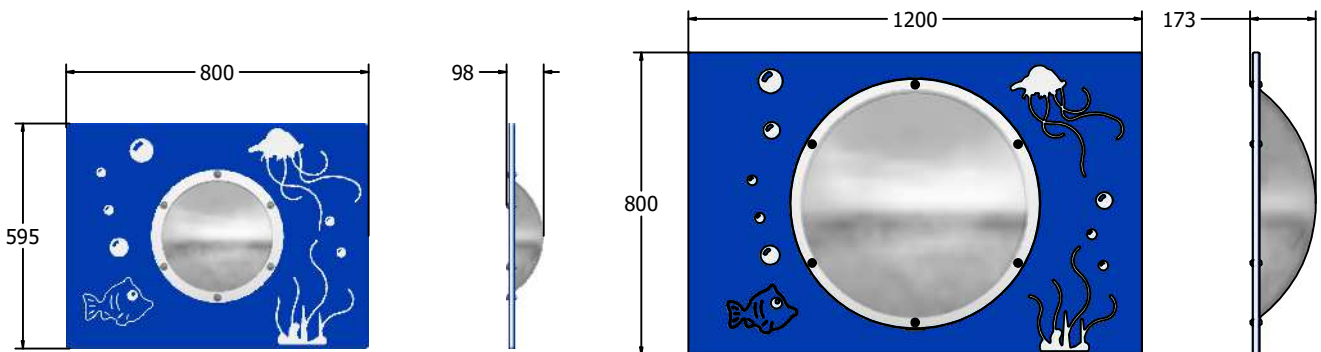

AMVFA-AP-FIBUBBLE6C

AMVFA-AP-FIBUBBLE3C

Age Range: 2+ Years  
 Largest Part: 800x595  
 Heaviest Part: 8Kg  
 Total Weight: 8Kg  
 Surfacing : N/A

Minimum Inspection Schedule	
Inspection Type	Inspection Frequency
Visual	Every Month
Functionality	Every Month
Comprehensive	Every 6 Months

Age Range: 2+ Years  
 Largest Part: 1200x800  
 Heaviest Part: 13.7Kg  
 Total Weight: 13.7Kg  
 Surfacing : N/A

Material: **Design Panel** - Two Colour High Density Polyethylene (HDPE) with orange peel texture finish  
**Polycarbonate Dome** - Shatter proof Polycarbonate

Colour Choices: **Design Panel** - Broad selection available, visit the website below for further details  
**Polycarbonate Dome** - Available in Clear, Mirror, Blue, Green, Red & Yellow