

Product Information

Eco-Bell Tree with Post

BS EN 1176 - Designed to British & European Standards

MATERIALS

Panels - Two Colour High Density Polyethylene (HDPE)

Post - 100% recycled plastic with a heavy textured finish

Bells - Stainless steel bells with brushed finish

SUPPLY METHOD

Bells - Partially assembled

Beaters - Assembled

Post - Supplied separately

FEATURES



INCLUSIVE - Bells positioned at easily accessible height



MUSICAL - Set of 3 musically tuned bells



DIMENSIONS

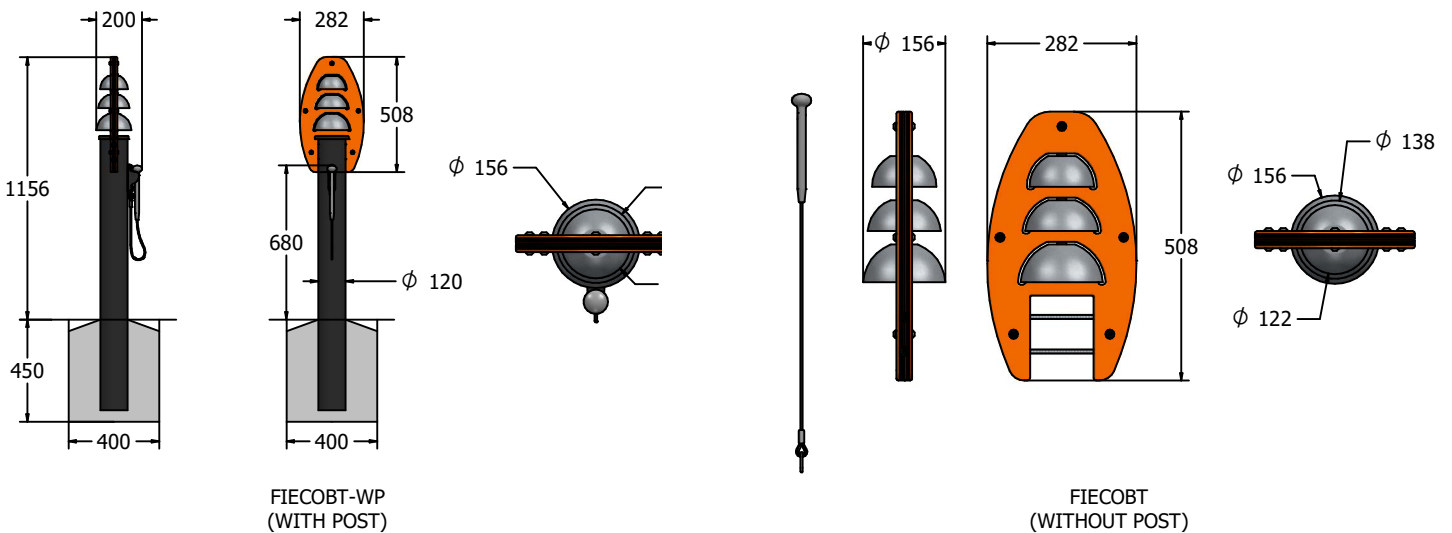

TECHNICAL

Age Range: 2+ Years
Largest Part: FIECOBT-WP - 1606 x 282 x 199mm
Total Weight: 16kg
Surfacing: N/A

Age Range: 2+ Years
Largest Part: FIECOBT - 508 x 282 x 156mm
Total Weight: 5kg
Surfacing: N/A