

Installation Instructions



Ground Fixed
Colossus Chimes
Page 1 of 2



Instrument Components:

Colossus Chimes are pre-assembled

Metric Conversion:
100mm/ 4"
250mm/ 10"
600mm/ 24"
1.5m/ 59"
1565mm/ 62"
2352mm/ 93"



1. Attach Ground Fixing posts to legs (1.2) (See Ground Fix Post Installation Sheet)

2. Excavate 11 holes for Emperor chimes 250mm diameter by 600mm deep in desired location upon decision from customer. 4 further holes will be needed for the beater poles according to layout of chimes at 250mm diameter and 400mm deep.

3. Locate (lower) legs into holes making sure they are vertical and level prior to concreting in place. Chimes fixings should be 50mm from ground surface.

4. Once happy with location of the chimes, fill holes using rapid hardening concrete. Be sure to compact concrete around legs and leave to dry according to manufactures guidelines.

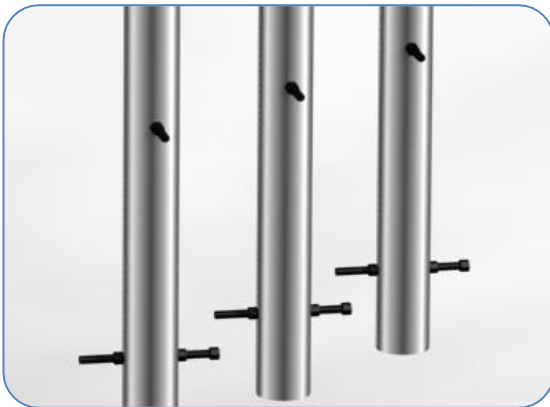

Weight of heaviest part 9kg (Chime)

In ground fixing always 600mm for each chime and 400mm for beater poles

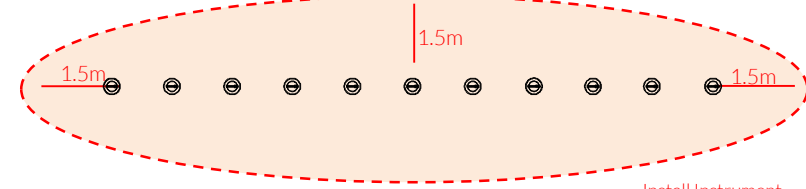

Install Instrument with 1.5m free space (from widest point) around it.

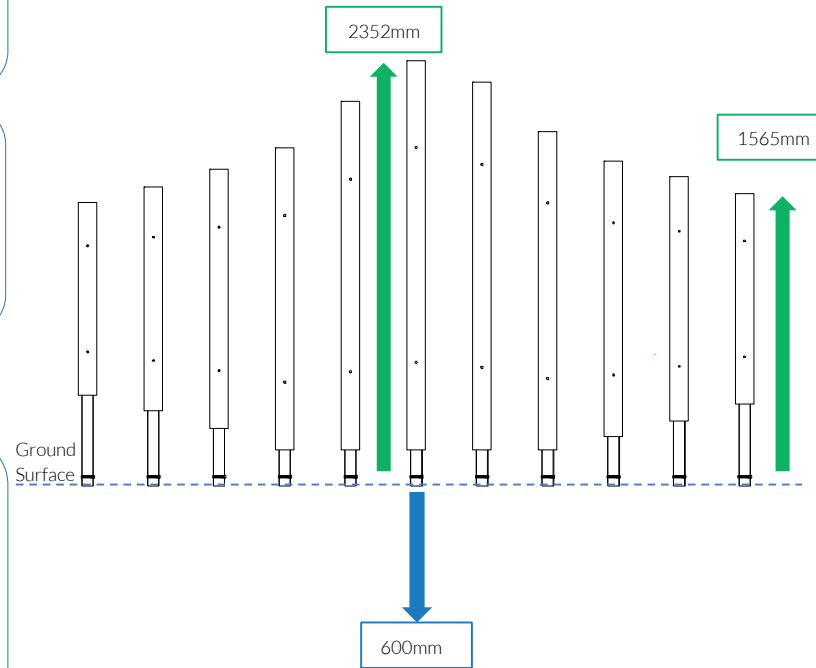

Played with hands

Ground Fix Components:

-  x22
M10x150 Bolt
-  x44
M10 Nut
-  x11
M10x50 Security Screw
-  x11
M10 Barrel Nut

130 Kg

Ground Fix Post Installation

Foundations should not present a hazard. These foundations are recommended as a guide, for more information on foundation details for various surface see Part 7 of BS EN 1176.

Thread Lock Solution
Required (Not Supplied)

Tools:



x2
TX 45 Driver Bit

Metric Conversion:
50mm/ 2"
100mm/ 4"
250mm/ 10"
350mm/ 14"
600mm/ 24"
650mm/ 26"

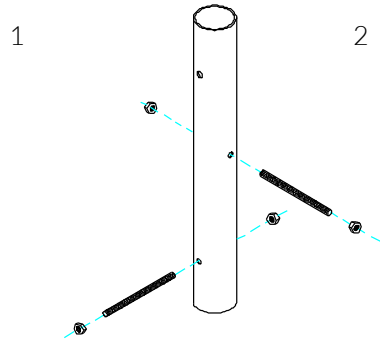

1 Insert M10x 150 Threaded bar into pre drilled holes in Ground Fixing Post

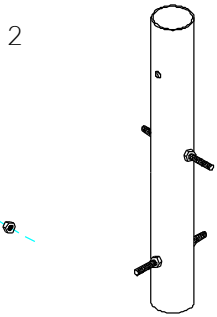

2 Fix M10x 150 Threaded bar in place using M10 Nuts

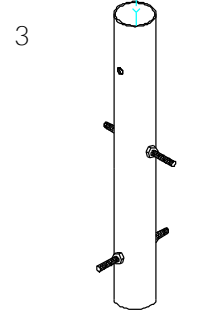

3 Locate the Ground fix Post into the leg of the instrument.

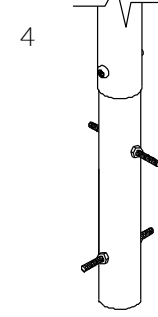

4 Fix instrument to Ground fix post using M10 bolt and Barrel Nut and use **thread locking solution** to prevent fixings working loose.

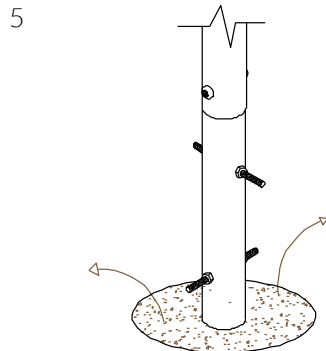

5 Excavate 11 holes with a 250mm diameter tapering down to 350mm diameter and 650mm depth

600mm max depth

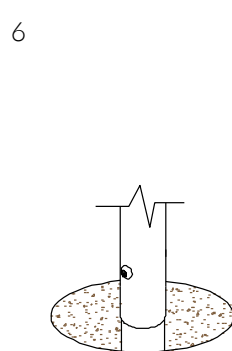

6 Compact base of hole with 50mm of aggregate. Lower ground Fix post attached to instrument into hole (check instrument straight and level before filling with concrete)

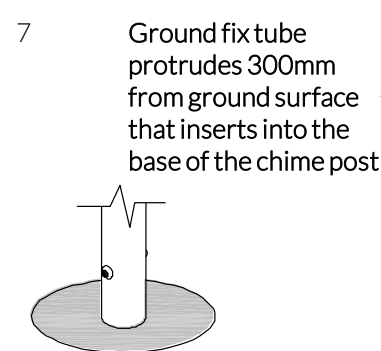

7 Fix hole with fast drying concrete to manufacturers specifications.

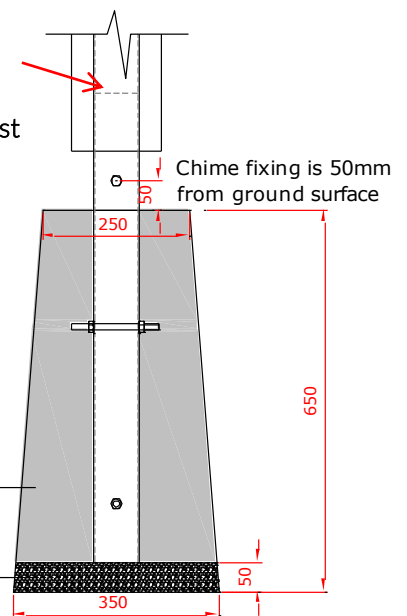

Ground Fixed Colossus Chimes Page 2 of 2



Components:

-  x22
M10x150 Threaded Bar
-  x44
M10 BZP Nut
-  x11
M10 Barrel Nut
-  x11
M10x50 Security Screw

Thread Lock Solution
Required (Not Supplied)