

Installation Instructions

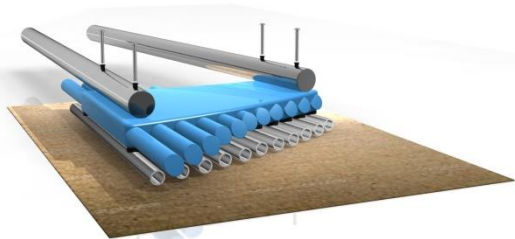

1. Carefully lay 2 x legs on a level surface and insert M10x200 bar and nuts. Using packing box as protection lay instrument note side down on the card. Line up pre drilled holes in the backboard with the legs and ensure the instrument is aligned square with the legs. **Fix in place using M10x100mm screws** supplied (see installation guide)

5. Beaters can be fixed to Stainless Steel posts with fixings provided

Install Instrument with 1.5m free space (from widest point) around it.

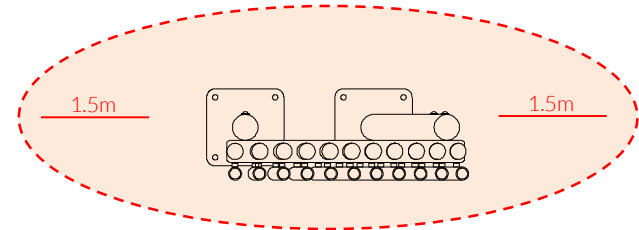

Surface Fixed

Cherub
Page 1 of 3

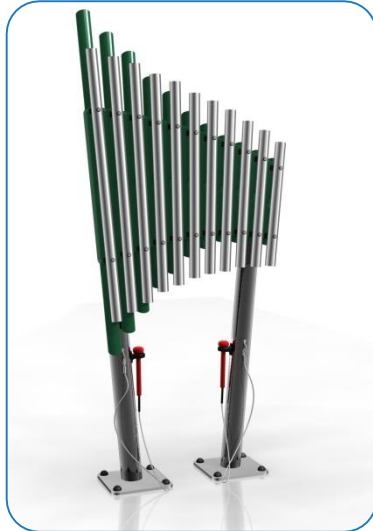

2. Attach surface plates to each leg with M10x70mm and Barrel nuts supplied. (See Surface Fix Installation Sheet)

3. Fix Surface Plates to level surface using Coachscrews, Rawlbolts, chemical anchors or similar as deemed appropriate by Installer.

(It is your responsibility to ensure that the existing surface is suitable to receive the appropriate fixing)

4 Make sure all fixings are covered and secure using cover caps provided

Metric Conversion:
500mm/ 20"
750mm/ 30"
900mm/ 35"
1100mm/ 43"
1.5m/ 59"

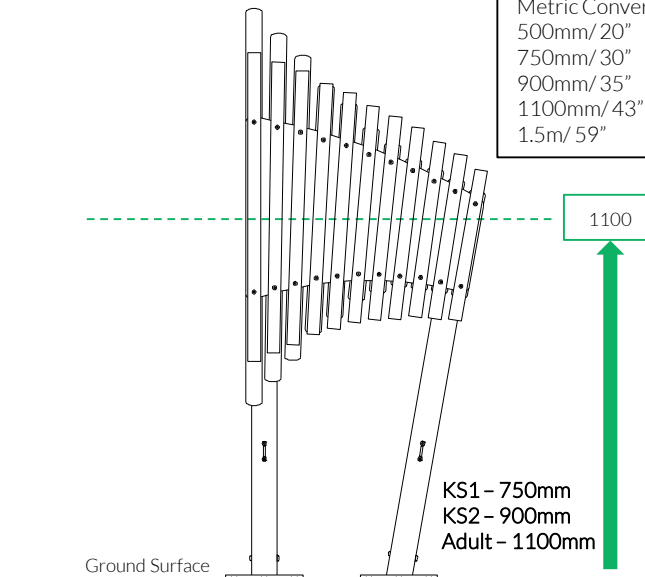

Components:



x4

M10x100 Security Screw



x2

Eye Straps



M6x20mm
Secure Screw



Weight of heaviest part 15kg



Pair Small
Beaters X1

Surface Fix
Components:



x2



x2



x8

M10x70 Security Screw M10 Barrel Nut 2 Part Cover Cap

Ground Anchors
not supplied

22 Kg

Assembly Guide PPSWAV



Surface Fixed

Cherub
Page 2 of 3



Components:



x4

M10x100 Security Screw



x2

Eye Straps



x4

M6x20mm
Secure Screw

Thread Lock Solution
Required (Not Supplied)



Pair Small
Beaters X1

Surface Fix
Components:



x2



x2



x8

Ground Anchors
not supplied

M10x70 Security Screw

M10 Barrel Nut

2 Part Cover Cap

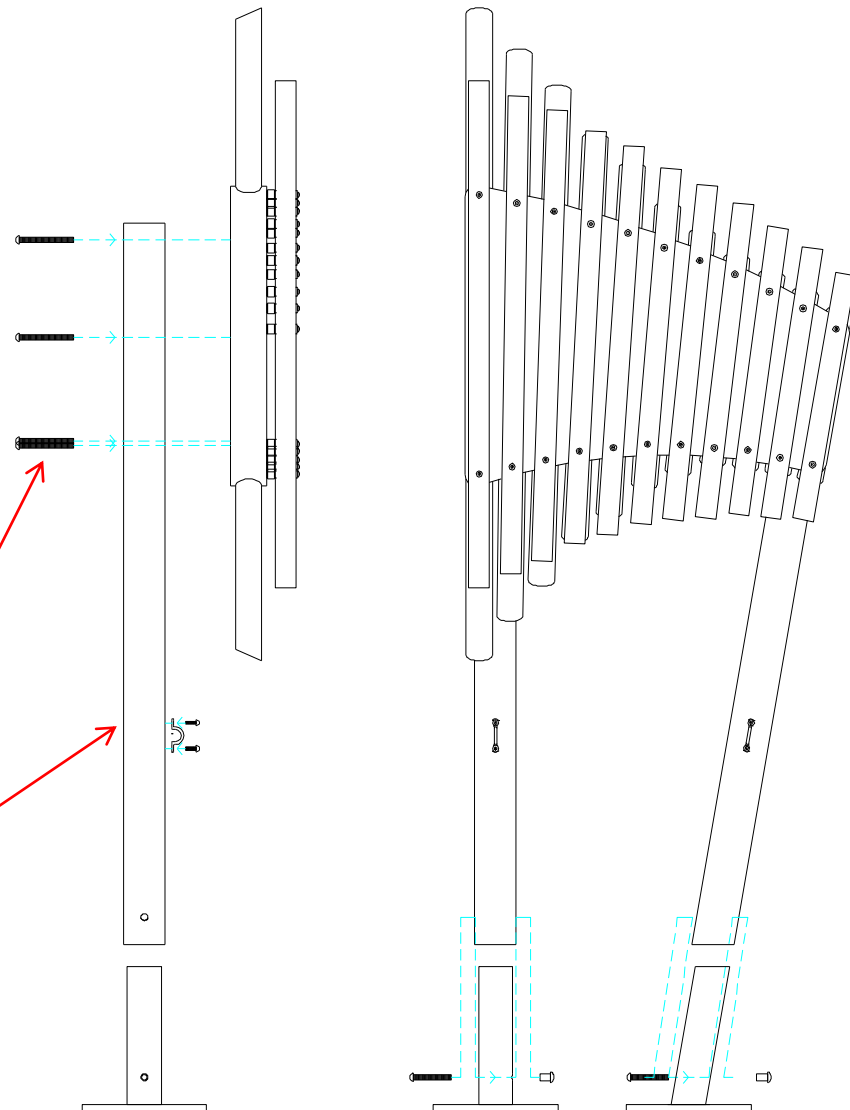

Tools:

x2

x1

TX 45 Driver Bit TX 30 Driver Bit

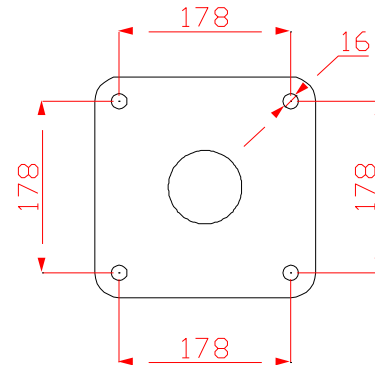

COMPONENTS LIST:



Saddle Strap X2



M6x20 Pin torx X4



M10x100 Pin torx X4



M10x70 Pin torx X2



M10 Barrel Nut Pin torx X2

22 Kg

Surface Fix Post Installation

Tools:

 x2
TX 45 Driver Bit



Surface Fixed

Cherub
Page 3 of 3



Components:



x2

M10 Barrel Nut



x2

M10x70 Security Screw



x8

2 Part Cover Cap

Thread Lock Solution
Required (Not Supplied)

1

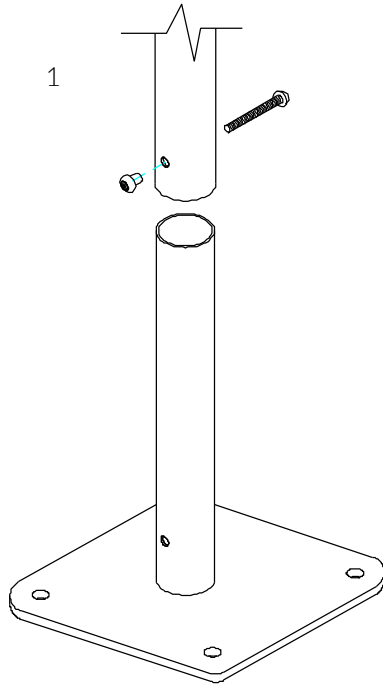

Locate the Surface fix Plate into the leg of the instrument.

2

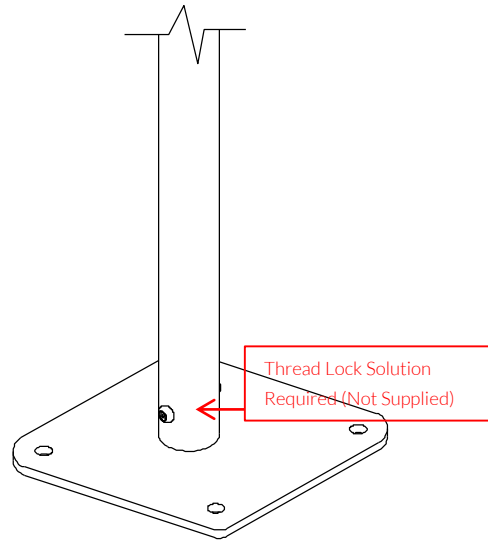

Fix instrument to Surface fix plate using M10 bolt and Barrel Nut and use **thread locking solution** to prevent fixings working loose.

3

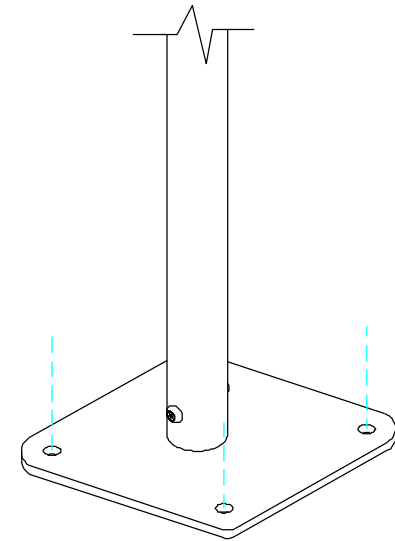

Fix Surface Plate to the ground surface **Ground Anchors Not provided** cover fixings with caps provided



MADE IN
BRITAIN

BSEN 1176