

Installation Instructions

Ground Fixed

Cajón
Page 1 of 3



Instrument Components:



Metric Conversion:
200mm/ 8"
400mm/ 16"
450mm/ 18"
1.5m/ 59"

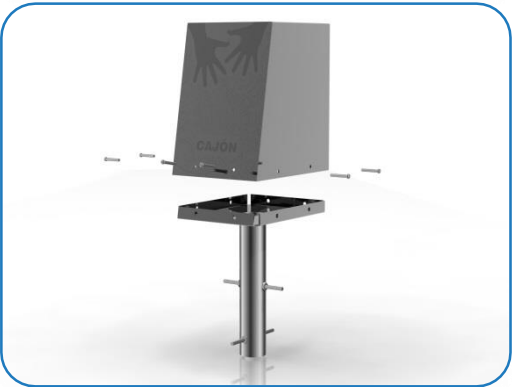

Weight of heaviest part 18kg (Cajón Drum)

1. Using **M10 nuts and 200mm bolts** supplied locate through pre drilled holes and secure bolts in place to support in ground pole in concrete. (See Assembly Guide)

2. **Attach Cajón** to ground fix plate and leg using **M8x25mm security screws** provided using thread lock solution not supplied.

3. **Excavate a hole** for the drum **200mm diameter by 450 deep** in desired location upon decision from customer. (See Ground Fix Post Installation)

4. Locate (lower) leg into hole making sure that the cajón is level on ground surface.

5. Once happy with location of the Drum, **fill** hole using rapid hardening **concrete**. Be sure to compact concrete around legs and leave to dry according to manufactures guidelines.

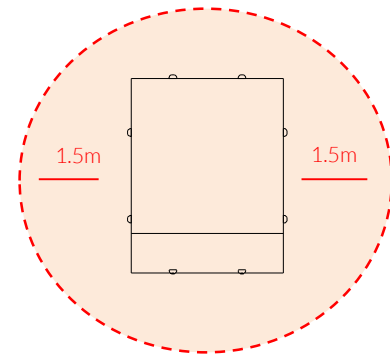

Install Instrument with 1.5m free space (from widest point) around it.

CAUTION: Drum surface can get hot in direct sunlight, if possible install in shaded areas.

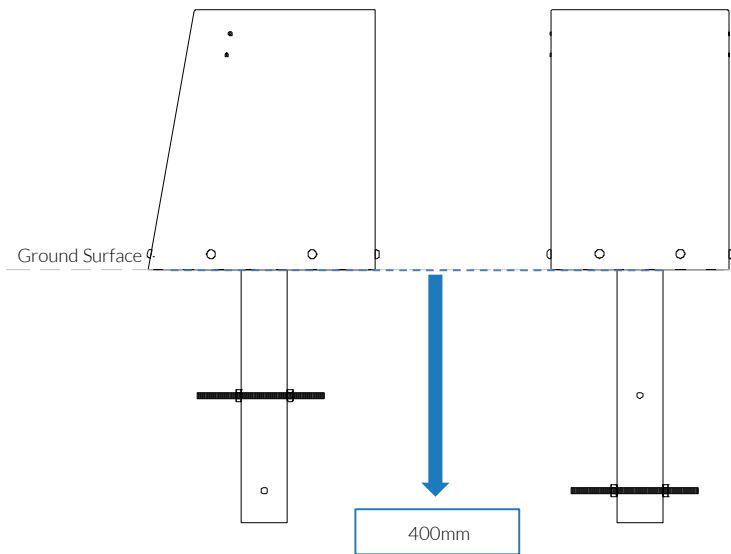

Ground Fix Components:



22 Kg

Assembly Guide Cajón



Ground Fixed

Cajón
Page 2 of 3



Instrument Components:



x8
M8x25mm Pin Torx

CAUTION: Drum surface can get hot in direct sunlight, if possible install in shaded areas.

Thread Lock Solution
Required (Not Supplied)



BS EN 1176

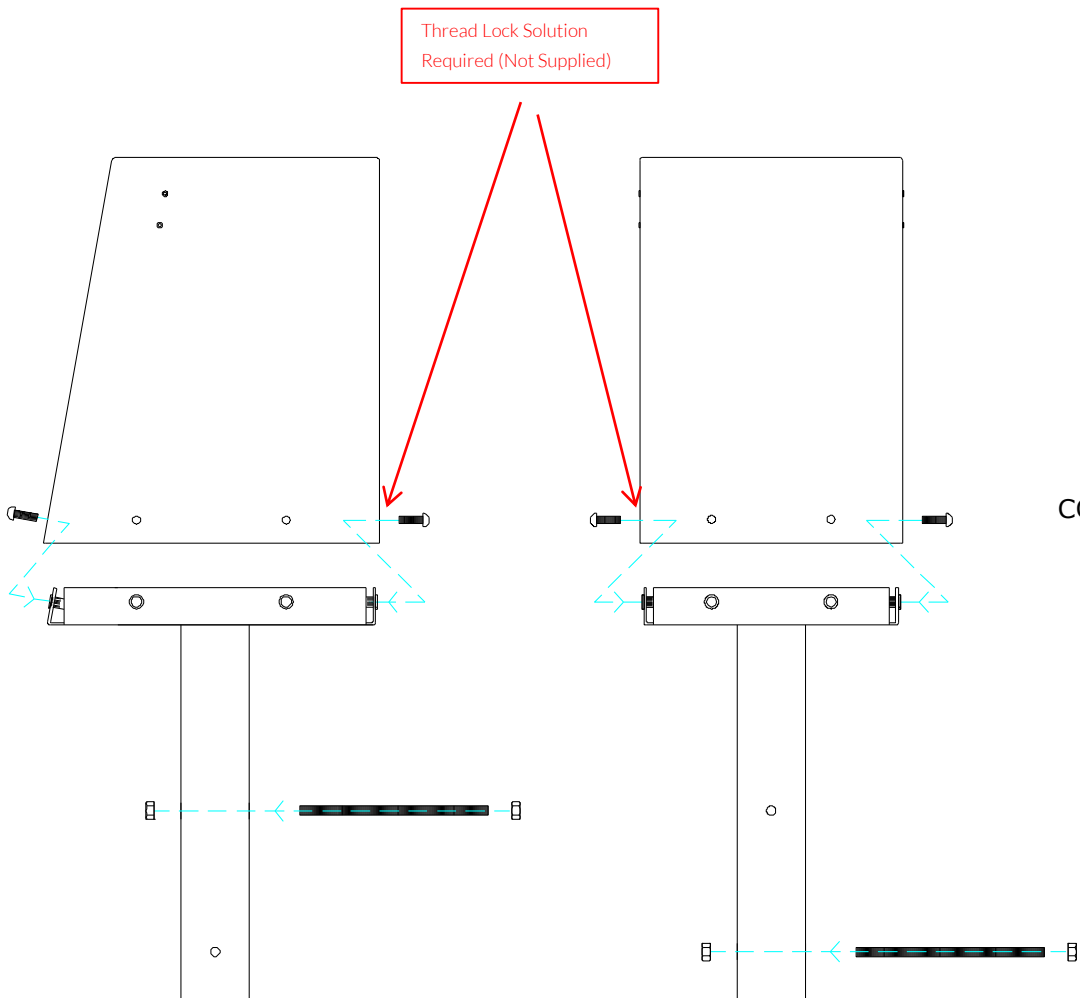

COMPONENTS LIST:

 M10 Nut X4

COMPONENTS LIST:

 M10x200 Threaded Bar X2

 M8x25 Pin torx X8

M10 Nut X4

M10x200 Threaded Bar X2

M8x25 Pin torx X8



Played with hands

Ground Fix Components:

 x2
M10x150 Threaded bar

 x4
M10 BZP Nut

22 Kg
13.4 Kg

Ground Fix Post Installation

Ground Fixed

Cajón
Page 3 of 3

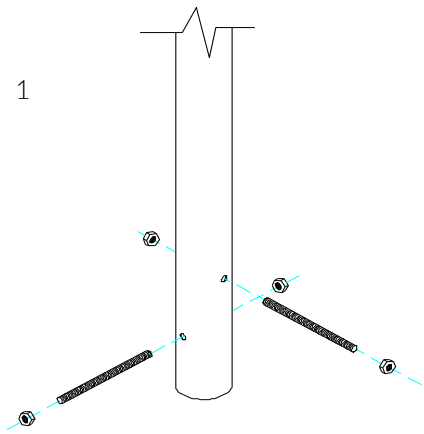

1
Insert M10x 200 Threaded bar into pre drilled holes in Ground Fixing Post

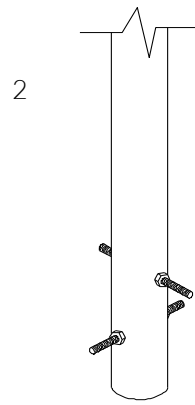

2
Fix M10x 200 Threaded bar in place using M10 Nuts

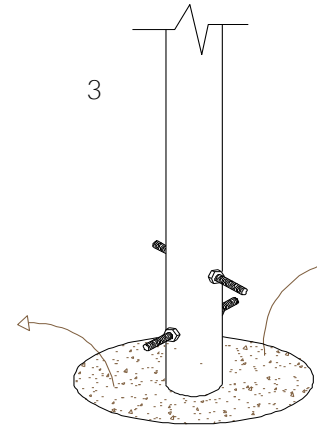

3
Excavate a hole with a 250mm diameter tapering down to 350mm diameter and 450mm depth

Foundations should not present a hazard. These foundations are recommended as a guide, for more information on foundation details for various surface see Part 7 of BS EN 1176.

4

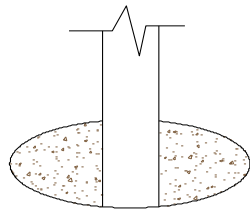

4
Compact base of hole with 50mm of aggregate. Lower ground Fix post attached of instrument into hole (check instrument straight and level before filling with concrete)

5

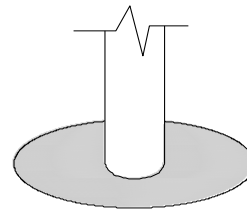

5
Fill hole with fast drying concrete to manufacturers specifications.

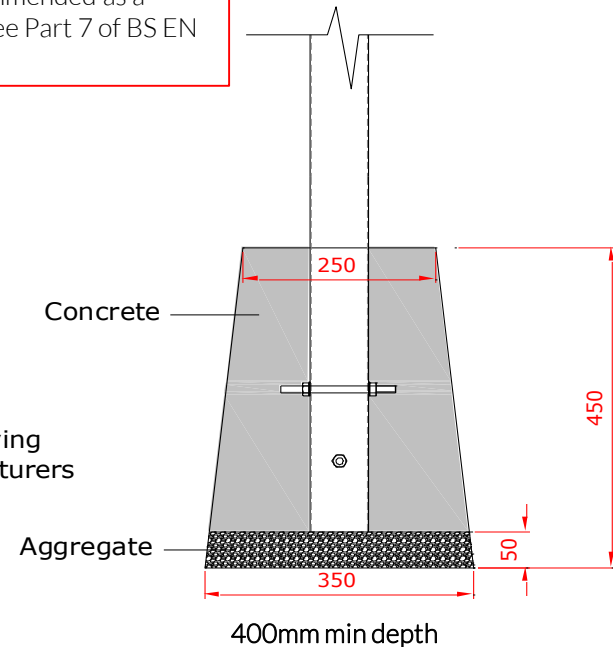

Components:



Metric Conversion:
50mm/ 2"
250mm/ 10"
350mm/ 14"
400mm/ 16"
450mm/ 18"

Thread Lock Solution
Required (Not Supplied)

