

Installation Instructions



1. Attach the steel legs to the base of the instrument with the M8 Nyloc Nuts and 2 part security caps. **(1.1)** (See Assembly Guide)

2. Attach Wall Fixing posts to legs **(1.2)** (See Ground Fix Post Installation Sheet)

3. Mark hole locations (X4) using the pre drilled holes in square plate.

4. Drill hole locations (X4) according to your chosen fixings (frame fixings, wall bolts or chemical anchors) depending of the structure of the wall. **(Not Supplied)**

5. Fix through Plate with suitable fixings (not supplied) in correct orientation and height for intended Key stage. Cover Fixings with 2 Part Caps supplied

6. Attach the 1 pair of beater to the saddle strap on the leg. **(1.3)**

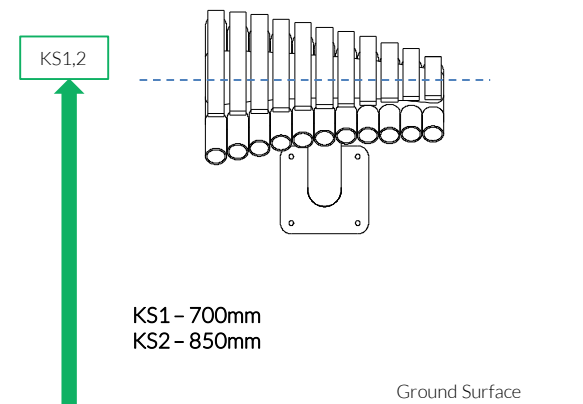
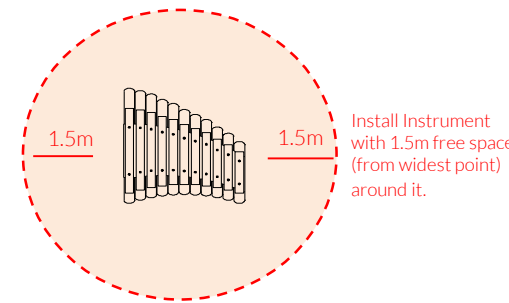

Weight of heaviest part **7kg** (Cadenza)

Wall Fixed

Cadenza
Page 1 of 2



Instrument Components:

-  x4
M8 Nyloc Nut
-  x2
M6x20 Security Screw
-  x4
2 Part Cover
-  x1
Cap
-  x1
M6 Saddle Strap

Metric Conversion:
250mm/ 10"
300mm/ 12"
450mm/ 18"
700mm/ 28"
850mm/ 33"
1.5m/ 59"

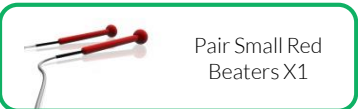

Wall Fix Components:



Wall Fixings/ Anchors not supplied

14 Kg

Assembly Guide PPCADE



Tools:

 x1
  x1

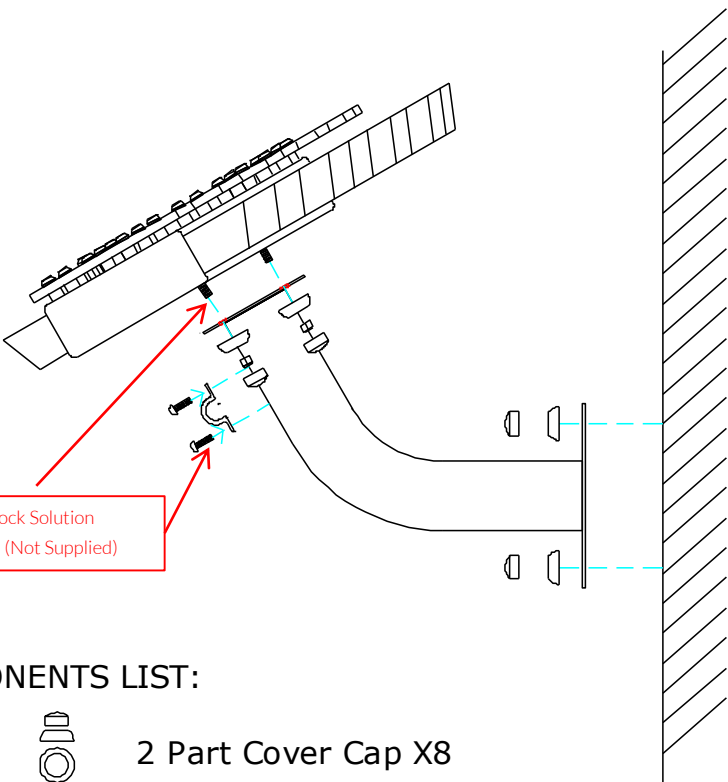

Wall Fixed

Cadenza
Page 2 of 2



Thread Lock Solution
Required (Not Supplied)

COMPONENTS LIST:

-  2 Part Cover Cap X8
-  M8 Nyloc nut X4
-  Saddle Strap X1
-  M6x20 Pin torx X2

Instrument Components:

-  x4
M8 Nyloc Nut
-  x2
M6x20 Security Screw
-  x4
2 Part Cover Cap
-  x1
Cap
-  x1
M6 Saddle Strap

Thread Lock Solution
Required (Not Supplied)

Pair Small Red Beaters X1

Wall Fix Components:

-  x4
2 Part Cover Cap

Wall Fixings/
Anchors not
supplied

14 Kg