

Installation Instructions

Surface Fixed

Cadenza
Page 1 of 3

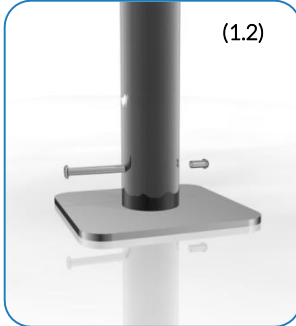

Weight of heaviest part 7kg (Cadenza)

1. Attach the steel legs to the base of the instrument with the M8 Nyloc Nuts and 2 part security caps. (1.1) (See Assembly Guide)

2. Attach Surface Fixing posts to legs (1.2) (See Ground Fix Post Installation Sheet)

3. Locate Plate in desired location and mark holes to fix to desired surface.

4. Fix to Surface using recommended ground anchors not supplied

5. Make sure all fixings are covered and secure using cover caps provided

6. Attach the 1 pair of beater to the saddle strap on the leg. (1.3)

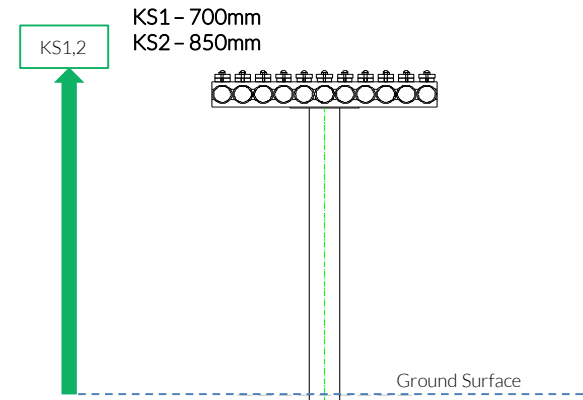
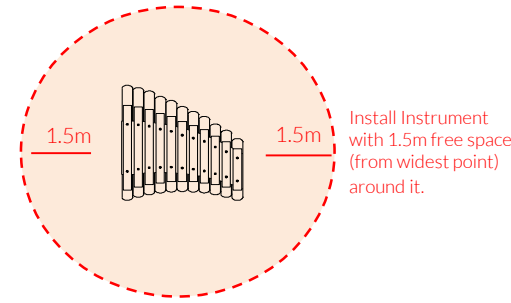

Instrument Components:

- x4
M8 Nyloc Nut
- x2
M6x20 Security Screw
- x4
2 Part Cover Cap
- x1
M6 Saddle Strap

Metric Conversion:
250mm/ 10"
300mm/ 12"
450mm/ 18"
700mm/ 28"
850mm/ 33"
1.5m/ 59"



- Surface Fix Components:
- x1
 - x1
 - x4

Ground Anchors not supplied

14 Kg

Assembly Guide PPCADE



Tools:

- x1
- x1

Surface Fixed

Cadenza
Page 2 of 3



Instrument Components:

- x4
- x2
- x4
- x1
- x1

Thread Lock Solution
Required (Not Supplied)

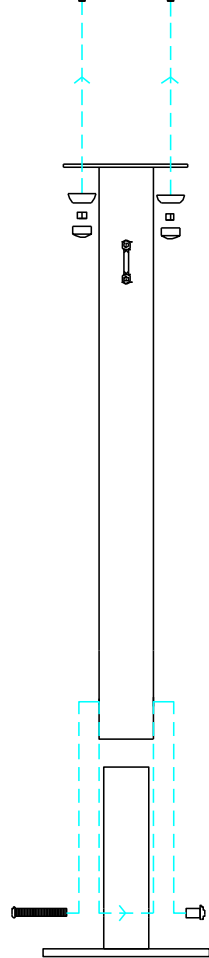
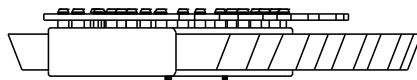
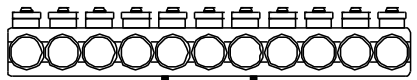

PPCADE FRONT

Thread Lock Solution
Required (Not Supplied)

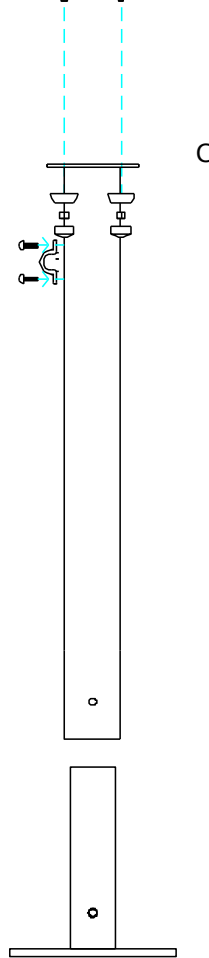

PPCADE SIDE

COMPONENTS LIST:

- 2 Part Cover Cap X4
- M8 Nyloc nut X4
- Saddle Strap X1
- M6x20 Pin torx X2
- M10x70 Pin torx X2
- M10 Barrel Nut Pin torx X2

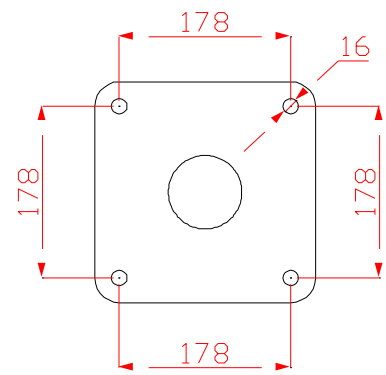

Pair Small Red Beaters X1

Surface Fix Components:

- x1
- x1
- x4

Ground Anchors
not supplied

14 Kg

Surface Fix Post Installation



Tools:



x2
TX 45 Driver Bit

Surface Fixed

Cadenza
Page 3 of 3



Components:



x1

M10 Barrel Nut



x1

M10x70 Security Screw



x4

2 Part Cover Cap

Thread Lock Solution
Required (Not Supplied)

Metric
Conversion:
50mm/ 2"
250mm/ 10"
350mm/ 14"
400mm/ 16"
450mm/ 18"

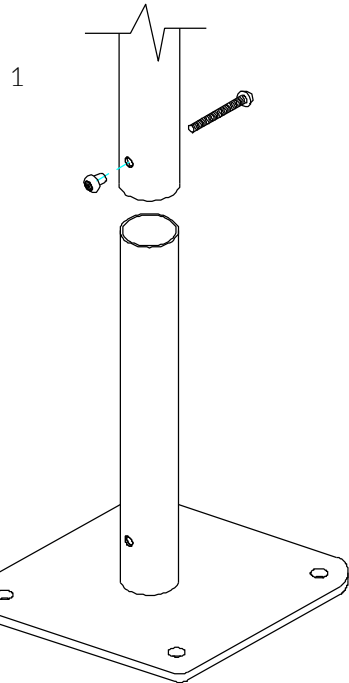

1
Locate the Surface fix Plate into the leg of the instrument.

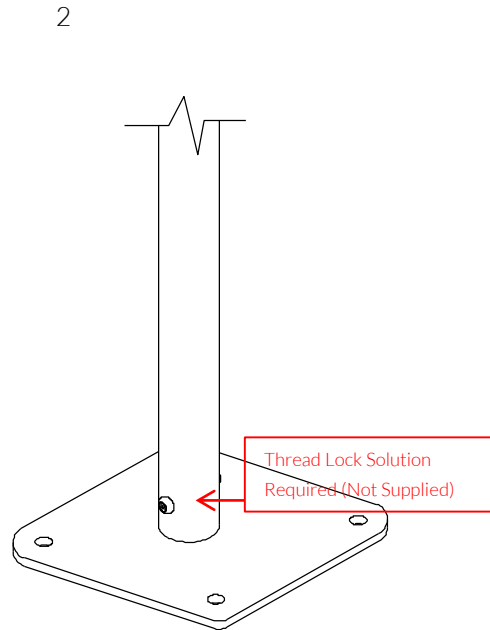

2
Fix instrument to Surface fix plate using M10 bolt and Barrel Nut and use **thread locking solution** to prevent fixings working loose.

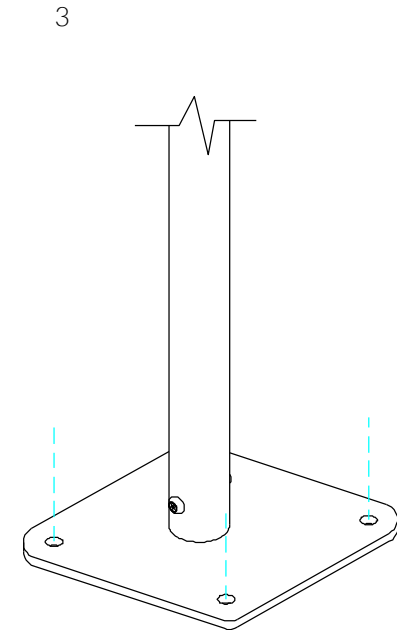

3
Fix Surface Plate to the ground surface **Ground Anchors Not provided** cover fixings with caps provided

Repeat Parts 1-3 for both legs



MADE IN
BRITAIN

BSEN 1176