

# Installation Instructions



**1. Assemble Akadinda frame** comprising 2x 'X'-shaped legs and 1x horizontal beam. (See **Assembly Guide**). Cover 8 holes on horizontal beam using **4xBlack caps (1.1)**

**2. Locate M8x80mm eye bolts** through pre drilled holes using flat washers on both sides of the timber to prevent the fixing pulling into the timber. Secure in place with **M8 nyloc nuts**, cover 4 holes in ends using **4xBlack caps. (1.2)(1.3)**

**3. Attach L Brackets** to legs of frame with coach bolts provided. Pilot holes required to stop timber from splitting

**4. Place Akadinda** in desired location and **mark 4 holes** for surface fixing.

**5. Fix to Surface** using recommended ground anchors not supplied

**6. Make sure** all fixings are covered and secure using cover caps provided

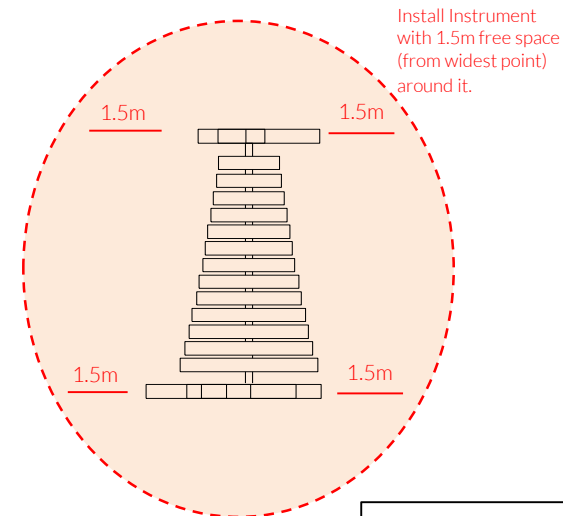

Metric Conversion:	
150mm/ 6"	
250mm/ 10"	
360mm/ 14"	
400mm/ 16"	
500mm/ 20"	
650mm/ 26"	
750mm/ 30"	
900mm/ 35"	
1.5m/ 59"	

Height to centre of notes:  
**KS0** 3-5 500mm Depth 400mm  
**KS1** 5-7 650mm Depth 250mm  
**KS2** 7-11 750mm Depth 150mm  
**Adult** 900mm Surface Mounted

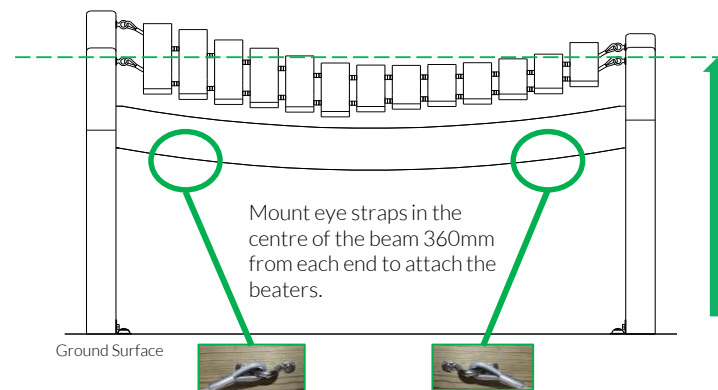

Weight of heaviest part **28kg (Frame)**

## Surface Fixed

Akadinda  
Page 1 of 2



### Instrument Components:

- M10 Wedge Nut X2
- M10x30 SS Washer X2
- M8x25 SS Washer X8
- Eye Straps X2
- M8 Lock Nut X4
- Pin Torx 25 Driver Bit X1
- M10x130 Bolt X2
- 10x38mm Secure Screw X4
- Black Caps X8
- 5x70mm Screw X4



### Surface Fix Components:

- M8x50 Coach Screw x8
- L Brackets x4
- 2 Part Cover Cap x4

Ground Anchors not supplied

48 Kg

# Assembly Guide PPAKAD

### Tools:

x1  
TX 25 Driver Bit

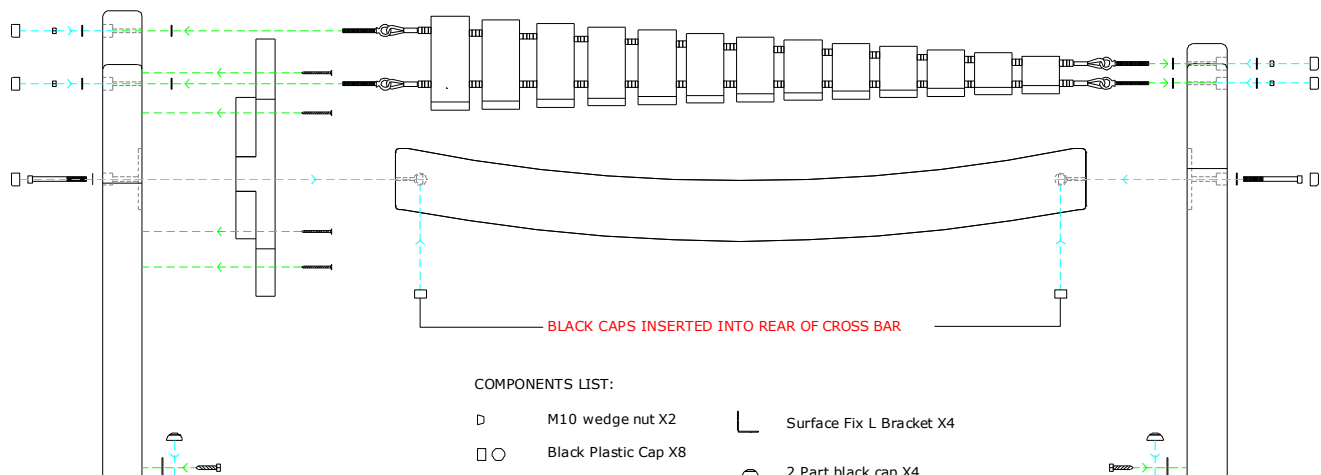

#### COMPONENTS LIST:

- D M10 wedge nut X2
- ○ Black Plastic Cap X8
- M10x130 Bolt X2
- | ⊙ M10x30 washer X2
- | ⊙ M8x25 washer X8
- 5x70 screw X4
- M8 Nyloc nut X4
- L Surface Fix L Bracket X4
- ∩ 2 Part black cap X4
- 8x50 Coach screw X4

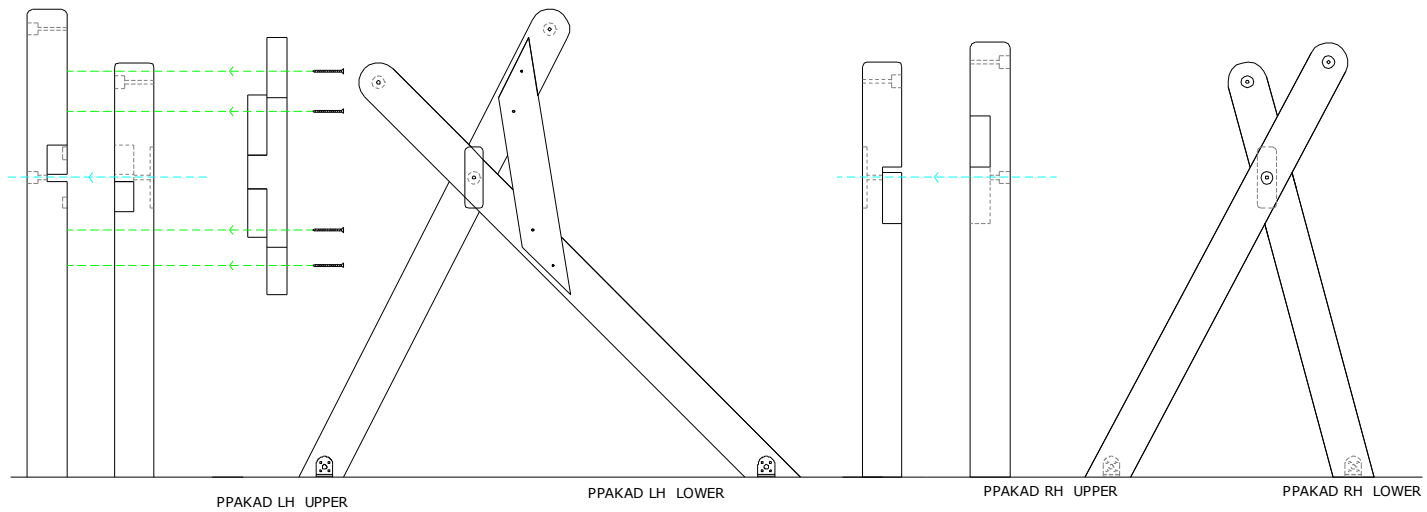

### Surface Fixed

Akadinda  
Page 2 of 2

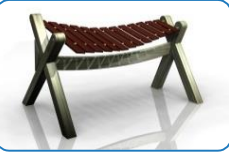

### Instrument Components:

- M10 Wedge Nut X2
- M10x30 SS Washer X2
- M8x25 SS Washer X8
- Eye Straps X2
- M8 Lock Nut X4
- 5x40mm Secure Screw X4
- M10x130 Bolt X2
- 5x70mm Screw X4
- Black Caps X8



Pair Large Red Beaters X2

### Surface Fix Components:

- M8x50 Coach Screw x4
- L Brackets x4
- 2 Part Cover Cap x4

Ground Anchors not supplied

48 Kg