

1.6m Wobble Board

Excavation Detail

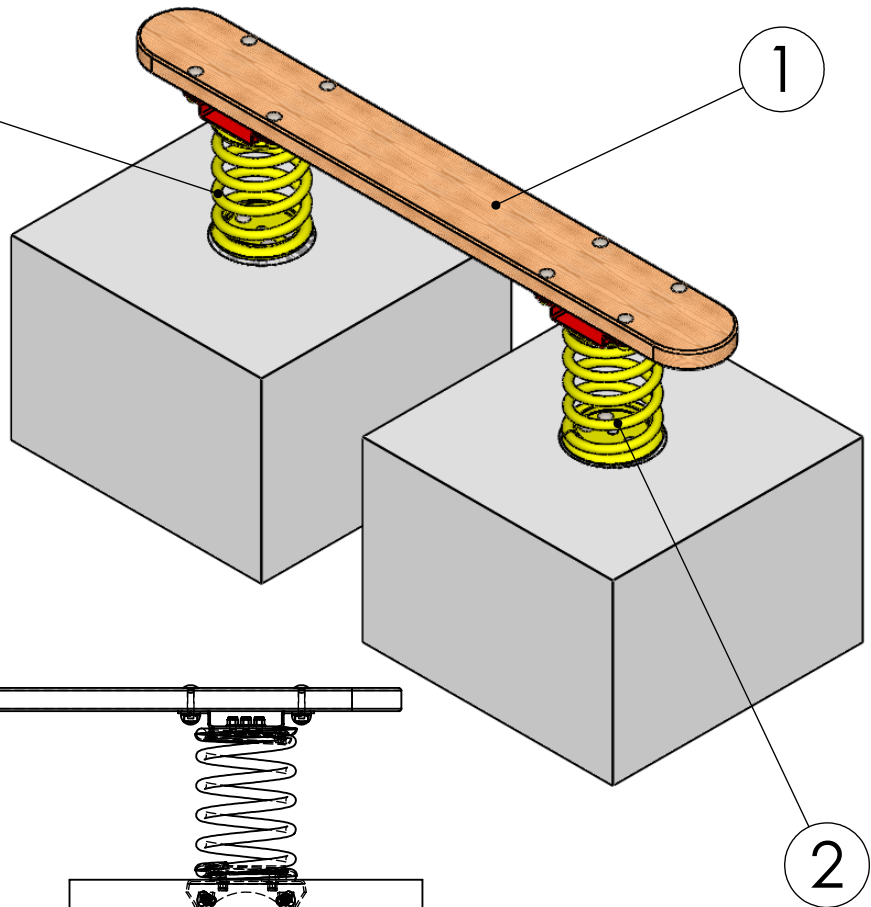

FFH: 380mm

No safety surface required as critical fall height is less than 600mm. However we suggest allowing an appropriate free space around the item in compliance with BS EN1176.

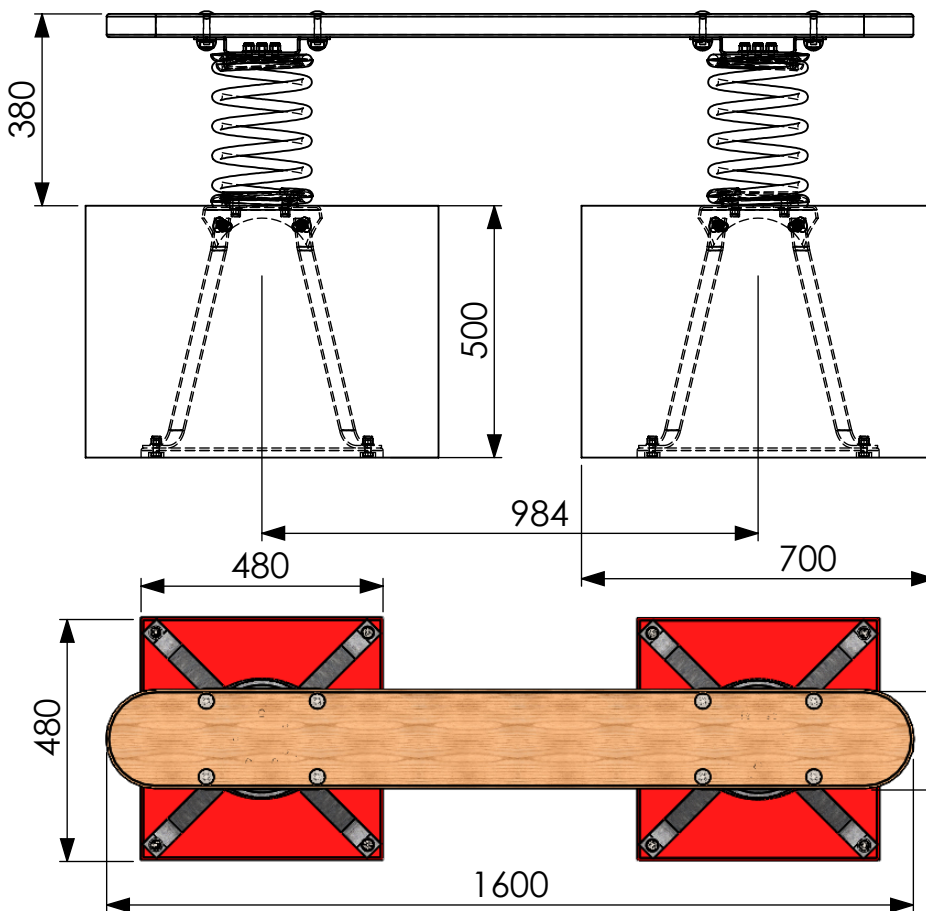

Dig ground works 500mm deep

This equipment for play areas is manufactured following the codes & practice outlined in the British and European standards and in so doing meets the requirements of BSEN 1176 (general safety and test methods).